

**General**

- ▶ The measuring unit consists of a sensor and a precision target wheel for mounting on shafts with diameters ranging from 8 mm to more than 500 mm.
- ▶ Measurement of speed and position by proximity sensing of precision target wheel with magneto-resistive sensor elements.
- ▶ Output signals are two 90° shifted sinusoidal signals for detection of sense of rotation (tracks 1 and 2) and their inverse signals. Optionally with a reference pulse (track N).
- ▶ Internal amplification and temperature compensation of sensor signals
- ▶ Certificate **Safety integrated**

Features

- ▶ Output signal level 1 V_{SS} with high quality
- ▶ Frequency range from 0 to 200 kHz
- ▶ Speed measuring range from 0 to 70.000 min⁻¹
- ▶ Temperature range -40 °C to +120 °C
- ▶ Protection class IP 68

Advantages

- ▶ Easy to install thanks to its optional amplitude control
- ▶ Extreme robust, fully encapsulated sensor
- ▶ Highly resistant to interference due to its metallic coating
- ▶ High flexibility in machine design through customised manufacturing of precision target wheels

Fields of application

- ▶ Machine tool engineering
 - Position and speed measurement of the main spindle in lathes, grinding and milling machines
 - Speed and position measuring in HSC spindles (High Speed Cutting)
 - Electronic synchronization of helical spindles in dry-running vacuum pumps
- ▶ Angle measurement in radar equipment
- ▶ Measurement of speed and position in test stands

Technical Data

Electrical Data	
Output level	1 V _{SS} (difference signal)
Output signal	two 90° phase-shifted sinusoidal signals and their inverse signals, short-circuit proof; optionally with reference pulse
Output frequency	0 to 200 kHz ⁽¹⁾
Offset (static)	± 20 mV
Amplitude tolerance	-20% to +10%
Amplitude ratio U _{TR1} / U _{TR2}	0.9 to 1.1
Supply voltage U _S	5 V DC ± 5%
Power consumption without load	≤ 0.3 W
Mechanical Data	
Module of the target wheel	0.3 / 0.5
Admissible air gap	0.15 mm ± 0.02 mm with module 0.3 0.2 mm ± 0.03 mm with module 0.5
Width of the target wheel	min. 4.0 mm
Material of the target wheel	Ferromagnetic steel
Max. admissible cable length	100 m (observe the voltage drop on the power line)
Working temperature	-30 °C to +85 °C
Operating and storage temperature	-40 °C to +120 °C
Protection class	IP 68
Electromagnetic compatibility	EN 61000-6-1 to 4 ⁽²⁾
Insulation stability	500 V, according to EN 60439-1
Vibration resistance	200 m/s ² , according to DIN EN 60068-2-6
Shock resistance	2000 m/s ² , according to DIN EN 60068-2-27
Weight	30 g
Housing	Polyphenylensulfid (PPS), fibre reinforced
Connection	Separate screen connection line for near-sensor earthing (e.g. using one fixing screw)
<ul style="list-style-type: none"> • Core x cross section • Outer diameter (O.D.) • Min. bending radius 	9 x 0.15 mm ² 5 _{-0.3} mm 25 mm

⁽¹⁾ at a line capacity of 5 nF

⁽²⁾ The normative limit values are met if mounting and connection jobs are carried out properly. Coaxial earthing of the MiniCoder connection cable (e.g. on the free cable end) and keeping the separate screen connection line as short as possible will additionally improve noise immunity.

Type code

2443	Signal pattern									
	K Sin/Cos signals 1 Vpp									
	Reference mark									
	- None									
	N Flag									
	M Groove									
	Z Flag aligned with tooth (recommended)									
	Amplitude control									
	R With									
	1 Without									
Cable outlet										
R Radial										
G Axial										
Module										
5 0.5										
3 0.3										
Connection type										
K Open cable end (fixed length: 30, 150, 250 or 600 cm)										
A 17-pin straight connector										
B 17-pin angular connector										
Cable length										
Number in cm										
Temperature sensor cable (2 m)										
M Included										
- None										
Separate screen connection on sensor										
E- Mandatory										

Signal pattern

$K = \text{Sine/Cosine signals } 1 V_{PP}$

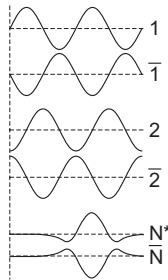
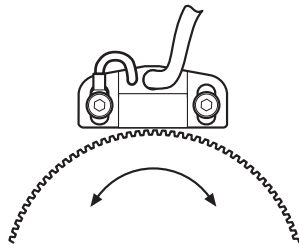

Reference signal (N, /N) only available with reference mark (N, M oder Z)

Reference marks

Reference marks may occur in the form of a groove or a flag. The flag must be made of ferromagnetic material and may not protrude beyond the gear-wheel of the target wheel. The selection of the reference mark is determined by the size and speed of the used target wheel, as both variables affect the forces acting on the reference mark.

For new designs, we recommend the use of target wheels with reference mark variant "Z".

Reference mark N – flag

A metal flag integrated in the target wheel is detected when its position is exactly between two teeth. This reference signal can be used as a position reference. This is required, for instance, for the automatic changing of a tool in a milling or grinding spindle.

Reference mark M – groove

Depending on size and geometry of the target wheel, the target wheel version with a reference flange can only be used up to certain speeds. For speeds beyond 30.000 min^{-1} , a MiniCoder detecting a reference groove integrated in the target wheel is used. For technical reasons, the target wheel is in this case composed of two parts.

Reference mark Z – flag aligned with tooth

This MiniCoder version can be used for scanning a target wheel manufactured in one piece. The system permits reaching speeds of more than 70.000 min^{-1} . The reference flag sits precisely on one tooth of the pulse track.

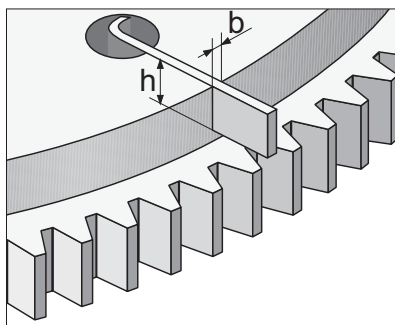

N = reference mark – flag

$h = 4 \text{ mm}$
 $b = 0.5 \text{ mm}$

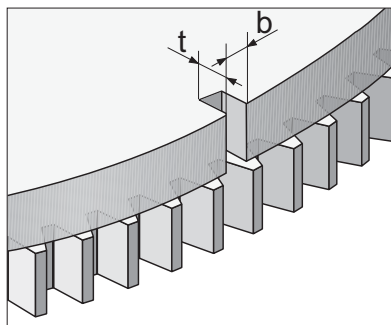

M = reference mark – groove

$t = 1 \text{ mm}$,
 $b = 1.2 \text{ mm}$ for module 0,3
 $b = 1.6 \text{ mm}$ for module 0.5

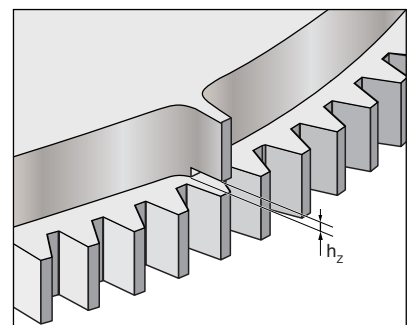

Z = reference mark – flag aligned with tooth

$h_z = 2 \text{ mm}$

Description

Amplitude control

The GEL 2443 MiniCoder offers facilities for stabilizing fluctuations in the sin/cos amplitudes resulting from changes to the measuring distance and temperature.

The assembly effort is reduced considerably. Readjustment is no longer needed to optimize the signals.

Cable outlet



G = Axial cable outlet

R = Radial cable outlet

Module

The module describes the relation between the number of teeth and the outer diameter of a target wheel. The smaller the module the smaller the outer diameter for the same number of teeth.

The air gap to be observed between sensor and target wheel is less with module 0.3 than with module 0.5.

Type	Module	Air gap d , adjusting characteristic	Distance tolerance
3	0.3	0.15 mm	± 0.02 mm
5	0.5	0.20 mm	± 0.03 mm

The MiniCoder must be ordered to match with the target wheel.

Cable length

For connection type K (open cable end), 4 cable lengths are available: 30, 150, 250, 600 cm. For cable assembling with plug connectors, the cable length must be given in cm.

Cable type PUR cable, screened, 9×0.15 mm²

Outside diameter: 5 mm (- 0.3)

Min. bending radius: 25 mm

Cable for temperature sensor (2 m)

Variants A and B can be delivered on request with the cable for the temperature sensor connected to the mating connector (see → [page 8](#)).

Cable type TEFLON cable, 2×0.14 mm²

Outside diameter: 2.8 mm (± 0.1)

Min. bending radius: 20 mm

Separate screen connection on sensor

This screen connection is connected to the screen of the sensor cable. In order to improve electromagnetic compatibility (EMC), the separate screen connection should be connected to the flange on which the MiniCoder is mounted.

Connection type

The MiniCoders are delivered with open cable end as type **K** or with 17-pole plug connectors (male) as type **A** or **B**. For connecting the plug connector, commercially available ready-made cables can be used.

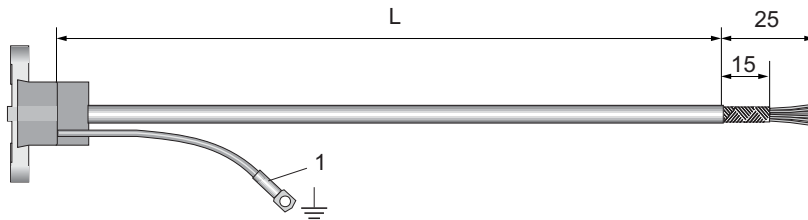

Connection type **K** open cable end

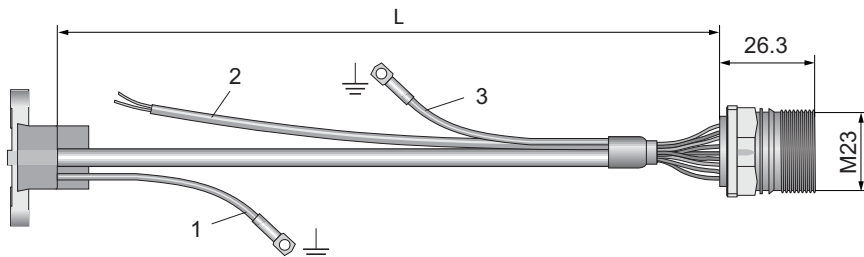

Connection type **A** 17-pole straight connector (male)

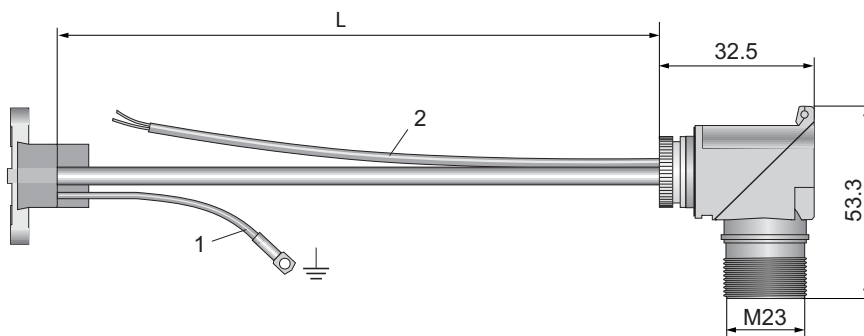

Connection type **B** 17-pole angular connector (male)

Key





- 1 Separate screen connection associated with cable screen. *)
- 2 Cable for temperature sensor, option **M** (2 cores, 2 m length)
- 3 Cable screen
- L Cable length (see type code)

*) Note: Fit the cable screening as coaxially to the earth cable as possible. When fitting the cable screening onto an earth cable, the earth cable should be run as short as possible.





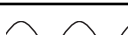
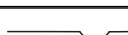

The connection types shown above are commonly used screen connection examples. Depending on type of control and cable used, a different screen may be necessary.

Connection

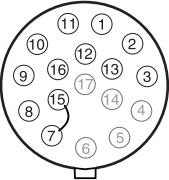
Connection type K

Open cable end	Lead colour		Signal / function		
	white	V_{1+}	Track 1		
	brown	V_{1-}	/Track 1		
	grey	V_{N+}	/Reference track		
	blue	0 V	GND		
	red	V_S	+ 5 V supply voltage		
	pink	V_{2+}	Track 2		
	black	V_{2-}	/Track 2		
	yellow	V_{N-}	/Reference track		
	green	V_{Sense}	5 V sense		

Connection type A or B

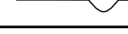
17-pin connector (male)	Lead colour		Pin		Signal / function		
 <p>Connection side view (solder/crimp side of the mating plug) Screening is not connected inside the MiniCoder. Jumper between pins 7 and 15 Temperature sensor pin 8 and 9</p>	white	1	V_{1+}	Track 1			
	brown	2	V_{1-}	/Track 1			
	grey	3	V_{N+}	Reference track			
		4 – 6	not connected				
	blue	7	0 V	GND			
	—	8	$\vartheta+$	Temperature +	(brown)		
	—	9	$\vartheta-$	Temperature –	(blue)		
	red	10	V_S	+ 5 V supply voltage			
	pink	11	V_{2+}	Track 2			
	black	12	V_{2-}	/Track 2			
	yellow	13	V_{N-}	/Reference track			
		14	nicht belegt				
	—	15	0 V	GND			
	green	16	V_{Sense}	5 V sense			
		17	not connected				

Customised target wheels

On request, customised target wheels are manufactured according to individual specifications. Please send us a dimensional drawing of your target wheel (if possible, as a dxf-file) to info@lenord.de.

Standard target wheels

For detecting rotary movements, the MiniCoders and target wheels form a complete unit. The target wheel size and hence, its diameter are directly dependent on the module and the number of teeth, i.e.:

$z = (d_a / m) - 2$ $d_a = m \cdot (z+2)$	d_a = outer diameter m = module z = number of teeth
---	---

Standard target wheels (design see table) are available at short notice ex factory.

Design of standard target wheels

number of teeth z	module m [mm]	outer ø d _a [mm]	inside ø standard [mm]	inside ø d _i max. [mm]	collar-ø d _r [mm]
100	0.5	51.0	12 H7	30 H7	47
125	0.5	63.5	12 H7	35 H7	60
128	0.5	65.0	12 H7	35 H7	61
200	0.5	101.0	12 H7	70 H7	97
250	0.3	75.6	12 H7	45 H7	72
250	0.5	126.0	25 H7	85 H7	122
256	0.3	77.4	12 H7	50 H7	74
256	0.5	129.0	25 H7	90 H7	125
360	0.3	108.6	25 H7	70 H7	105
500	0.3	150.6	25 H7	110 H7	147
512	0.3	154.2	25 H7	110 H7	151

① reference mark
 ② target wheel

ø - Diameter

Type code for standard target wheels

	Reference mark	N with reference mark (flag) - without reference mark
	Module	3 Module 0.3 5 Module 0.5
	Number of teeth	see table "design of standard target wheels"
	Inside diameter	see table "design of standard target wheels"
ZA		

Accessories

Testing device GEL 210

For proper functioning, the MiniCoder must be adjusted precisely to comply with the tolerance limits. With the testing device GEL 210 the sine and cosine wave signals of the encoder are checked for admissible signal levels. The 3½-digit LC display (background lightened) displays the following measurands:

- ▶ Amplitude of sine and cosine track (voltage)
- ▶ Offset values of both signal tracks (voltage)
- ▶ Phase deviation between signal tracks with respect to 90°
- ▶ Correct function of reference track (voltage)
- ▶ Position detection of reference signal

The measured values can be compared with the required tolerance values, and verified accordingly.



Interpolation electronics

The MiniCoder's 1 VPP output signals are generally interpolated by the installed controller. If your controller does not offer this facility, Lenord + Bauer can supply standalone interpolation electronics units from its series GEL 212, GEL 213 or GEL 214. These convert the 1 VPP output signals to TTL square-wave signals (maximum interpolation factor = 512). We will be happy to send you our product documentation on request, or you can simply visit our website at www.lenord.de and download it from.

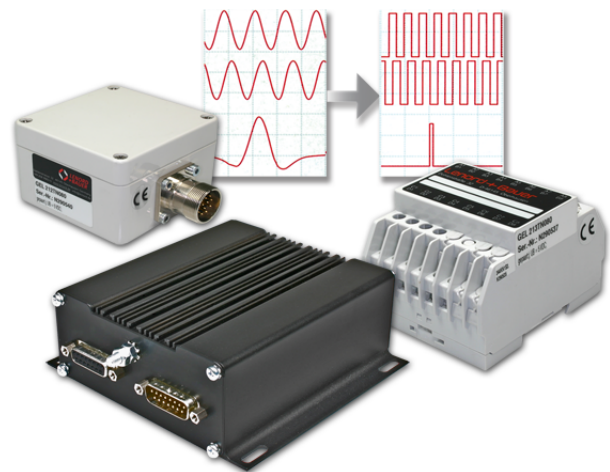

Your notes:

We have agencies in:

Austria
Belgium
Canada
China
Czech Republic
Denmark
Finland
France
Germany
Great Britain
Israel
Italy
Korea
Malaysia
Netherlands
Norway
Portugal
Sweden
Switzerland
Spain
Turkey
USA



Lenord, Bauer & Co. GmbH
Dohlenstraße 32
46145 Oberhausen, Deutschland
Phone: +49 208 9963-0
Fax: +49 208 676292
Internet: www.lenord.de
E-Mail: info@lenord.de

Subject to technical modifications and typographical errors.
The latest version can be downloaded at www.lenord.de.

