

Multi-function control MotionPLC GEL 8230/8231 GEL 8235/8236

PLC and positioning functionality

MOTIONLINE

LENORD+BAUER

Technical information

version 09.09



▲ GEL 8230/8231

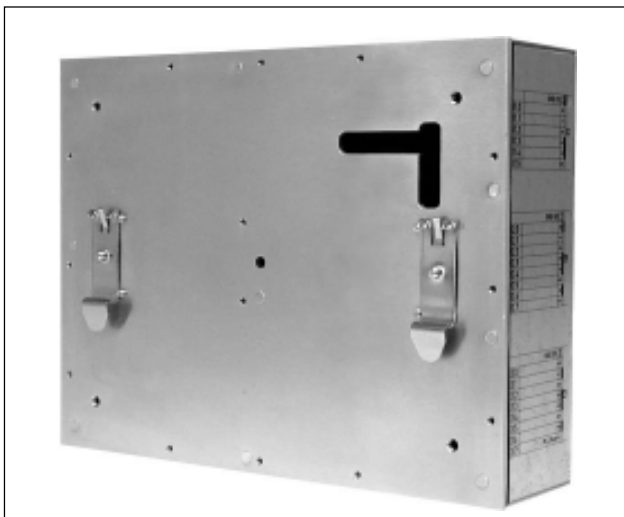

▲ GEL 8235/8236

General information

The controllers have an integrated PLC, field bus systems and multi-axis control with a maximum of 6 controlled axes. 64 axes altogether can be controlled via the CAN bus (without feedback). Additional inputs and outputs permit several CAN REMOTE I/Os with up to 64 inputs or outputs per node and up to 64 node addresses.

The standard CoDeSys programming environment runs in parallel with the multi-axis control and offers full transparency for all parameters. Parametrization of all 6 axes is effected by a PC tool and offers menu-guidance for comfortable setting of the usual parameters.

The standard programming environment in acc. with IEC 61131-3 includes a library of ready-made and powerful technology functions for terminal programming and automatic motion control.

Up to four different communication channels are available with one interface enabling all conventional field bus systems (PROFIBUS-DP, DeviceNet,...) to be used. The field bus modules can be retrofitted or replaced at any time without the need to modify the PLC program. The MotionController differ only in design (see below).

Characteristics of the MotionController

GEL 823x

- - RAM: 1 MBytes altogether
- - NVRAM: 8 kByte altogether
- - Flash: 1 MByte altogether
- - free memory space for PLC applications: 256 kBytes
- 2 CAN bus interfaces (servoconverter, CAN REMOTE I/O module)
- 2 asynchronous interfaces (one optionally RS 232 or RS 485 and RS 422)
- high noise immunity due to electrically isolated digital and analog inputs and outputs
- 3 encoder inputs (SSI, incremental, 5 V / 24 V)
- short projecting times due to ready-made functional blocks and pre-configured inputs and outputs
- drive control
 - analogue for ± 10 V power amplifier
 - ramp control
 - CAN bus for digital r.p.m.
 - clock output for stepping motor
 - binary signals for fast/slow speed drive

Device variants

	GEL 8240	GEL 8241	GEL 8245	GEL 8246
LCD and key panel	yes	yes	no	no
Digital inputs	22	30	22	30
Digital outputs	15	15	15	15
Analogue inputs	1	3	1	3
PT 100 inputs	0	4	0	4
Analogue outputs	3	3	3	3

GEL 8230/8231 (built-in device)

Key panel and rear view

Key panel

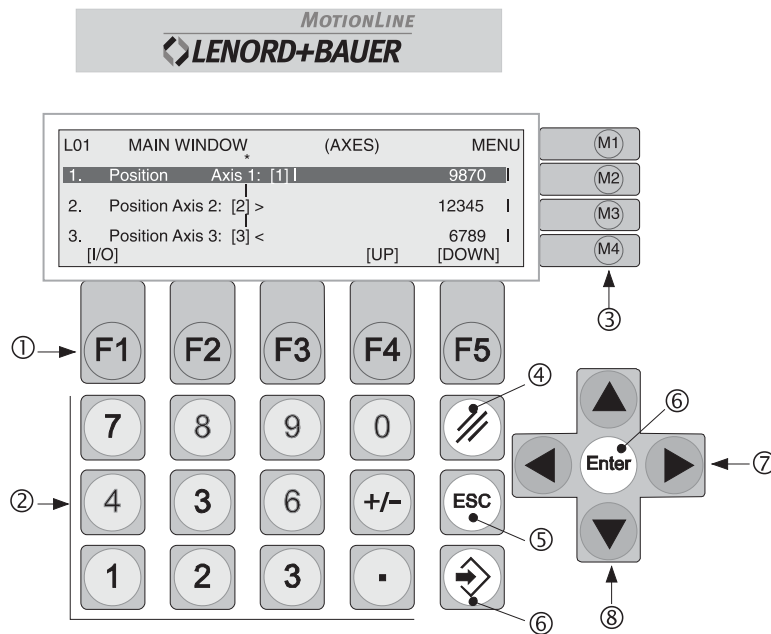

- ① Function keys (key assignment depending on active window)
- ② Numerical keys
- ③ Menu keys
- ④ Delete entered value
- ⑤ Abort entry/function and return to next higher menu level
- ⑥ Confirm entry
- ⑦ Selection keys
- ⑧ Scrolling keys

Using your own labelling strips, the inscription of the keys in groups ① and ③ and the company logo can be adapted to individual needs.

Rear view

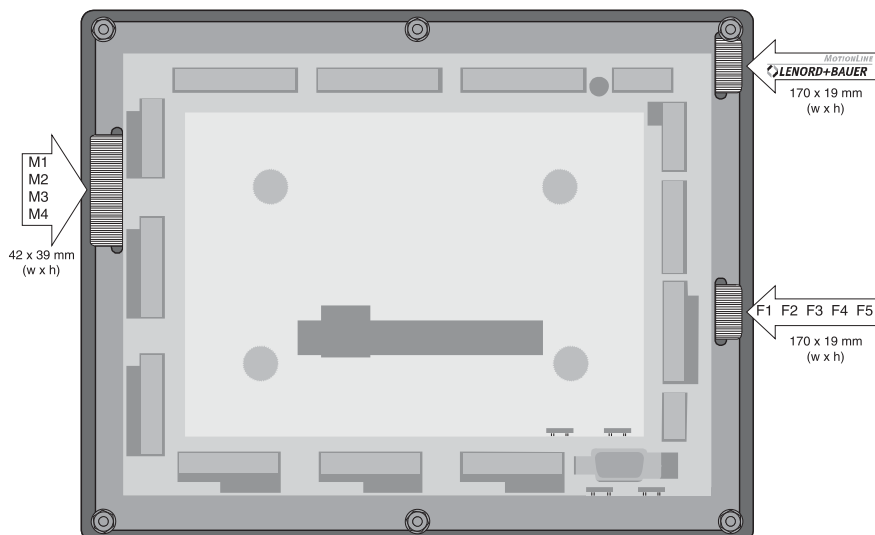

GEL 8235/8236 (top hat rail assembly) Front- and rear view

Rear view

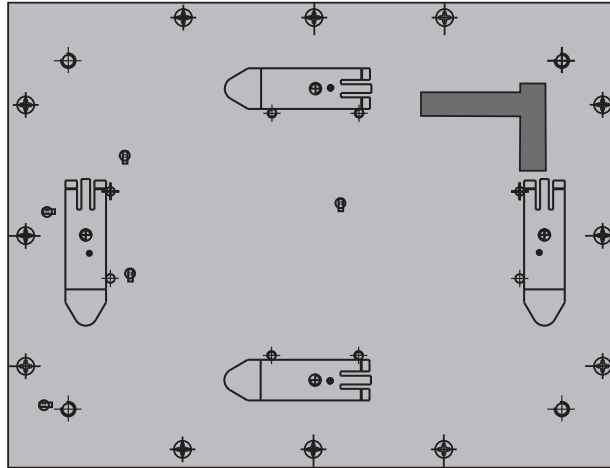

Front view

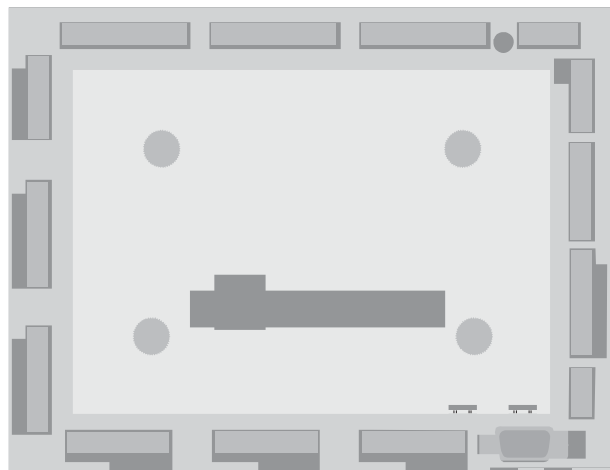

Technical data

	GEL 8230/8235	GEL 8231/8236
supply voltage	19 to 30 V DC	
power consumption	1 A max. (depending on interface)	
Interfaces (galvanically separated)		
serial (communication or programming)	two RS 232 C, usable as RS 232 C, RS 422 or RS 485 adjustable baud rate	
CAN bus (feedback, control, synchronisation)	two (CANopen and CANlink)	
extension slot (communication)	optional for one fieldbus module: PROFIBUS DP, InterBus-S, DeviceNet and for others on request	
Encoder inputs (actual-value inputs, galvanically separated)		
counting inputs	3 incremental or absolute (5 V, 24 V, SSI) freely combinable	
input frequency	200 kHz max.	
sensor supply loading	24 V, 900 mA / 5 V, 600 mA in total	
Inputs (galvanically separated)		
digital inputs	22 x 24 V, status indication by green LED	30 x 24 V, status indication by green LED
analogue inputs (max. 10 bit resolution)	1, selectable alternatively (0 to 10 V or 0 to 20 mA)	3, selectable alternatively (0 to 10 V or 0 to 20 mA)
PT100 inputs	-	4 (-40 °C to + 350°C)
Outputs (galvanically separated)		
digital outputs	9 x 24 V, 30 mA 6 x 24 V, 500 mA status indication by red LED	
analogue outputs	3 x ± 10 V, I _{max} = 10 mA, resolution 2 mV	
Climatic utilization category (KWF) according to DIN 40040		
working temperature range	0° to +50°C	
operating temperature range	-20°C to +50°C	
storage temperature range	-20°C to +70°C	
relative humidity	up to 95%, no condensation	
EMV (observance of the assembly instructions)		
electromagnetic emissions	DIN EN 61000-6-4 ¹⁾	
electromagnetic immunity	DIN EN 61000-6-2	
All devices is conform to EU directive EMC 89/336/EEC and provided with the CE mark.		
Display (only GEL 8230/8231)		
display	LC display with 64 x 240 pixels with LED backlighting	
visible area	133 mm x 39 mm	
Housing		
material	galvanized steel sheeting	
front panel	edge-protected aluminium	
weight	approx. 1.7 kg	
Protection class DIN 40050		
	GEL 8230/8231	GEL 8235/8236
front side	IP 65	IP 20
rear side	IP 20	

¹⁾ When using the devices in residential areas or in commercial or industrial environments the requirements as to electromagnetic emission defined in EN 61000-6-3 can be complied with by applying additional shieldings and filters.

Pin layout

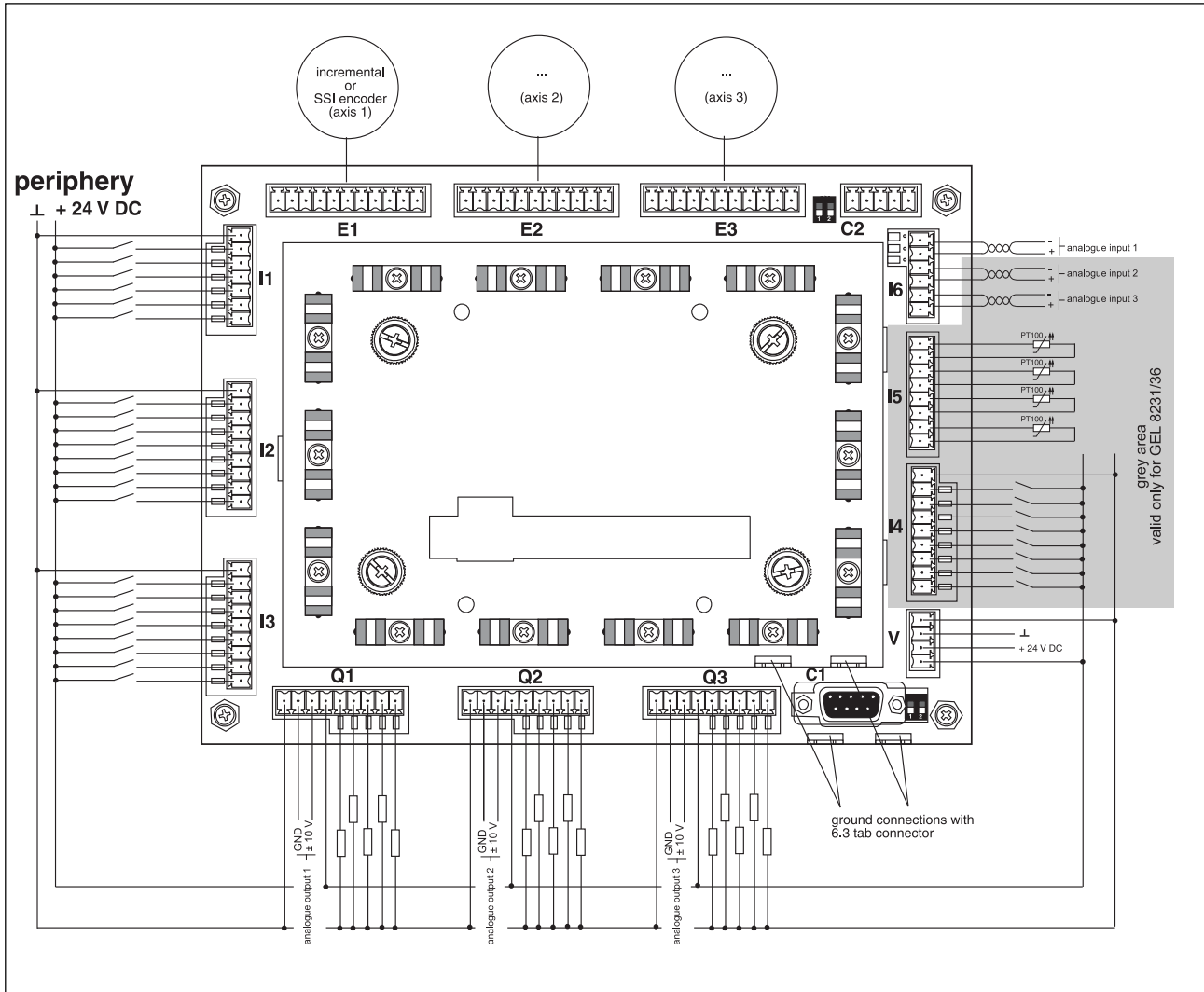

Terminal strip E1, E2, E3 (actual-value for axis 1, 2 or 3)

	E1	5 V	24 V	SSI	PWM	Function
GND (E)		GND encoder	GND encoder	GND encoder		terminal strip V
+5 V DC Out		supply *				terminal strip V
+24 V DC Out			supply**			terminal strip V
PWM/CLK_SSI+				clock SSI	clock SM	
PWM/CLK_SSI-				clock SSI	clock SM	
INCR_1+/Data_SSI+		track 1	track 1	data		0°, counter, data
INCR_1-/Data_SSI-		track 1		data		
INCR_2+		track 2	track 2			90°, direction, data
INCR_2-		track 2				
INCR_N+		N	N			reference fine
INCR_N-		N				

* from terminal strip V (U_E) internally regulated to 5 V; **direct from terminal strip V (U_E)
clock SM = clock stepping motor

Terminal strip C2 (CAN bus)

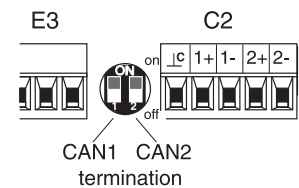
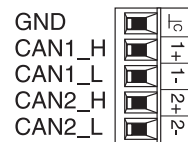

Pin layout

Terminal strip I1, I2, I3 and I4 (digital inputs)

I1	I2	I3	I4	I1/I2 I3/I4	signal	function
⊥ I1	⊥ I2	⊥ I3	⊥ I4		GND	optocoupler supply ← not interconnected
I1.0 / I2.0 / I3.0 / I4.0					input	*
I1.1 / I2.1 / I3.1 / I4.1					input	*
I1.2 / I2.2 / I3.2 / I4.2					input	*
I1.3 / I2.3 / I3.3 / I4.3					input	*
I1.4 / I2.4 / I3.4 / I4.4					input	*
I1.5 / I2.5 / I3.5 / I4.5					input	*
I2.6 / I3.6 / I4.6					input	*
I2.7 / I3.7 / I4.7					input	*, SPS RUN for I3.7

additional valid only * assignment (start, stop) defined by technology
GEL 8231/GEL 8236 function selected; can be adapted at any time

Terminal strip V (supply 24 V)

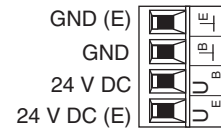

U_B = logical supply
U_E = encoder supply

Terminal input I5 (analogue input)

PT 100 inputs (-40 ... + 350 ° C)

I5	signal	function
	AE 1.4	GND
	AE 1.4	analogue
	AE 1.5	GND
	AE 1.5	analogue
	AE 1.6	GND
	AE 1.6	analogue
	AE 1.7	GND
	AE 1.7	analogue

analogue-In-
analogue-In+
analogue-In-
.
.
.
.
.

analogue-In-
analogue-In+
analogue-In-
.
.
.

Terminal input I6 (analogue input)

(0 ... + 20 mA or 0 ... + 10 V)

I6	signal	function
	AE1.1	analogue -
	AE1.1	analogue +
	AE1.2	analogue -
	AE1.2	analogue +
	AE1.3	analogue -
	AE1.3	analogue +

jumper position for

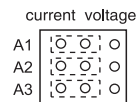

position as delivered: current

grey area
valid only for GEL 8231/8236

Terminal strip Q1, Q2, Q3 (outputs for axis 1, 2 or 3)

Q1	Q2	Q3	Q1/Q2 Q3/Q4	signal	function
⊥ Q1	⊥ Q2	⊥ Q3		GND	driver **
Q10- / Q20- / Q30-					analogue output 1, 2, 3 0 V ***
Q10+ / Q20+ / Q30+					analogue output 1, 2, 3 ± 10 V ***
24 V DC In / 24 V DC In / 24 V DC In					supply driver **
Q1.0 / Q2.0 / Q3.0					output 30 mA *
Q1.1 / Q2.1 / Q3.1					output 30 mA *
Q1.2 / Q2.2 / Q3.2					output 30 mA *
Q1.3 / Q2.3 / Q3.3					output 500 mA
Q1.4 / Q2.4 / Q3.4					output 500 mA

* assignment (start, stop) defined by technology function selected; can be adapted at any time

** terminal strip Q1/Q2/Q3 not interconnected

*** terminal strip Q1/Q2/Q3 interconnected

Connector C1 (9-pole sub-D miniature connector)

(9-pole sub-D miniature connector)

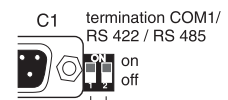
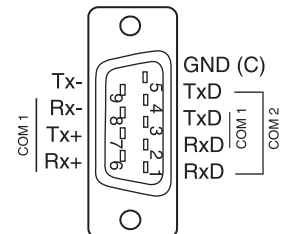

PLC programming environment

PLC programming environment

IEC 1131-3 is an international standard for programming languages adapted to stored-program control units. The programming languages realized in **CoDeSys** are in conformity with the requirements of the standard. They can be mixed whenever needed and are partially convertible.

The advantages of CoDeSys

General

- The CoDeSys programming languages are standardized.
- The CoDeSys programming languages can be freely mixed with one another.
- Fast compiler.
- One file per project.

Comfortable editor

- Automatic declaration of variables (auto declare).
- Automatic formatting of variables (auto format).
- Input assistance.
- Global find-and-replace function.
- Context-sensitive help.
- Context-sensitive menu.

Comfortable online debugging

- Online tracing of variables and their graphical representation.
- Setting of breakpoints.
- Single Step.
- Visible online variables without creating a list.
- Changing the variables while the control system is in operation.

Technical data

Type	CoDeSys IEC 61131-3
PLC program memory	256 kByte
PLC RAM	128 kByte
PLC flash	128 kByte
PLC NV RAM	4 kByte
Cycle time per 1000 STL code lines	approx. 2 ms

The CoDeSys programming languages

CoDeSys supports all five languages as per IEC 61131-3.

- Instruction List (IL)

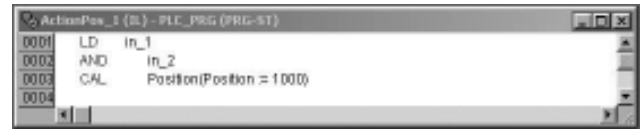

- Ladder Diagram (LD)

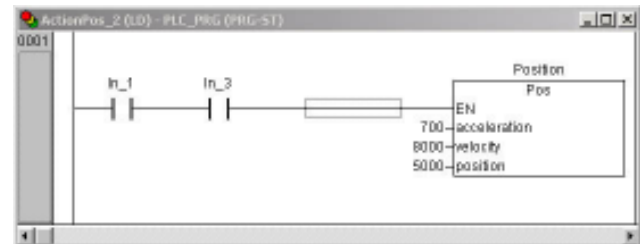

- Functions Block Diagram (FBD)

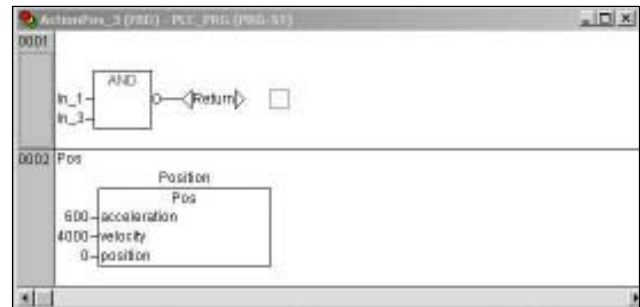

- Structured text (ST)



- Sequential Function Chart (SFC)

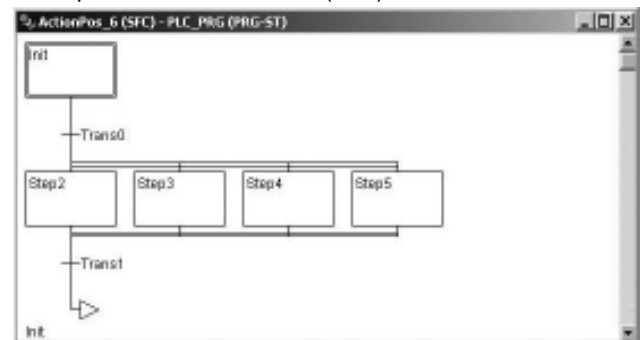

- Continuous Function Chart (CFC)

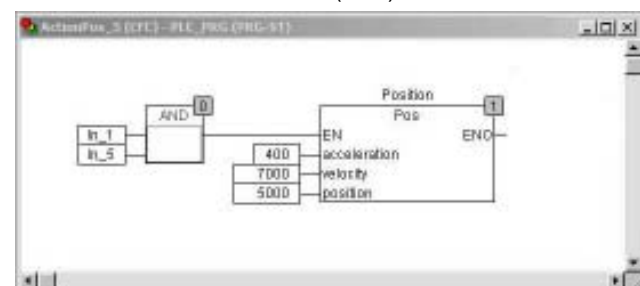

Automatic declaration of variables

After the entry of a still undeclared variable, a dialog box will appear where this variable can be declared. The new variable will then be transferred automatically in the correct format to the declaration part of the editor.

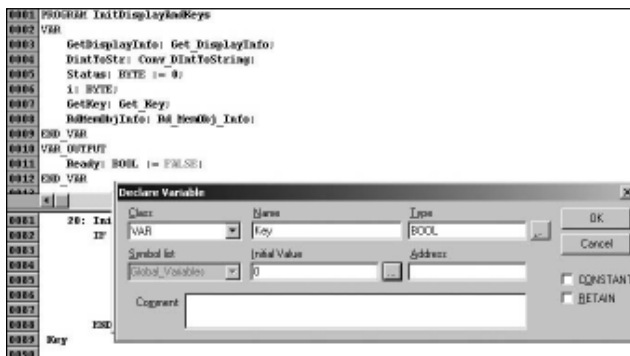

Automatic formatting of variables

During the declaration of a variable, the new variable will be automatically taken over into the declaration part of the editor in the correct format, including its initial values and address.

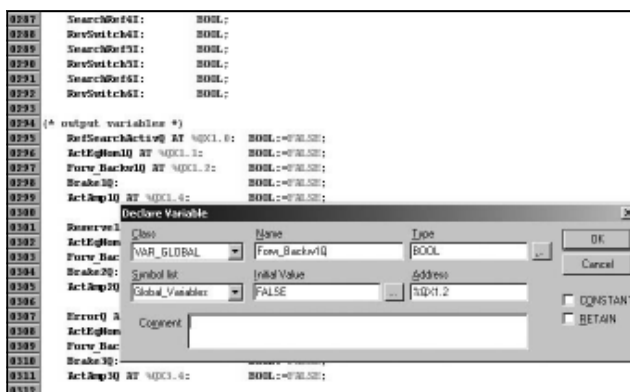

Context-sensitive help function

CoDeSys offers universal context-sensitive online help. It can be started by simply highlighting the respective keyword and by pressing key F1.

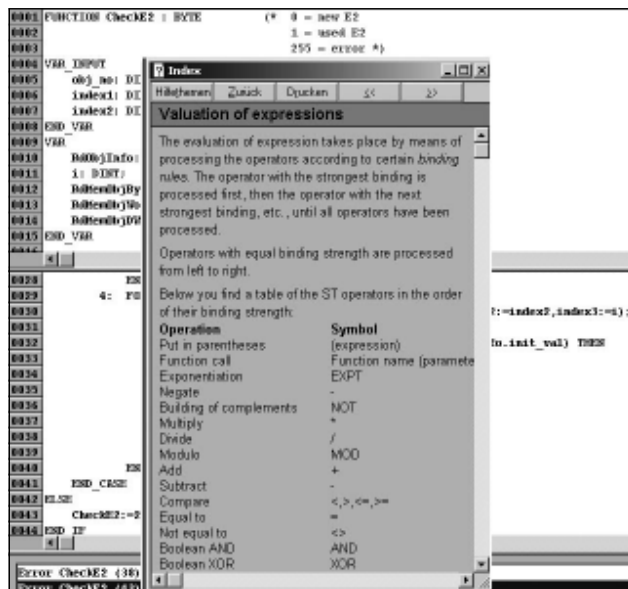

Context-sensitive menu

Clicking the right mouse button gives access to the most important commands within the entire working area.

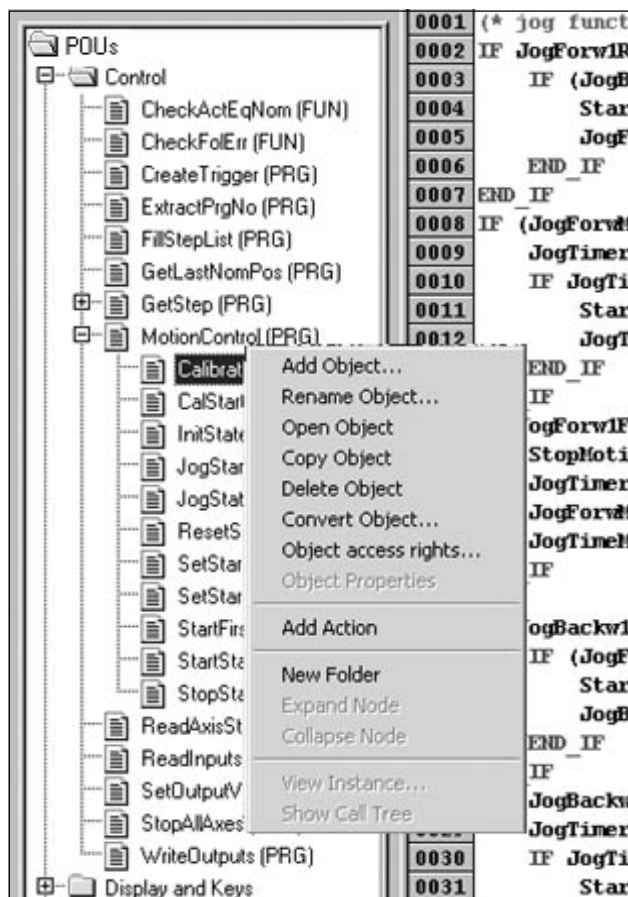

Function libraries, Integrated positioning controller

GEL 823x function libraries

In addition to the PLC standard modules available in the CoDeSys, Lenord + Bauer offer further function libraries for the GEL 823x which are supplied with the device. Among other things, they offer the following advantages:

- Complete, comprehensive and complex technology functions for quick and economic solutions.
- Simple, comfortable, self-explaining function blocks.
- Comfortable display control.
- Simple field bus communication with all MotionLine devices.
- Integrated in the GEL 823x operating system, therefore no utilization of PLC resources.

The GEL 823x function libraries include the most important function modules for:

- Positioning of axes.
- Reading in of positions and speeds.
- Reading in and reading out of digital and analog signals.
- Field bus communication.
- PWM output.
- Parameter management.
- Memory management.
- Display control and device information.

These CoDeSys modules are solely based on functions of the GEL 823x operating system and will thus not use up any PLC resources.

The following function libraries are available to the GEL 8230:

- Standard.lib
- MC8230_Basic.lib
- MC8230_HMI_Basic.lib
- MC8230_HMI_Techno.lib

Integrated positioning controller

A positioning controller and the necessary hardware for up to six axes are already integrated in the GEL 823x. Therefore, no additional modules will be needed. The GEL 823x offers the following control options:

- In binary form through a rapid feed/creep feed/stop function.
- Clock output for stepping motor.
- In analog form through a ± 10 V interface.
- Ramp control.
- In digital form through a CANopen interface.

For the traversing of axes, the GEL 8230 function library offers the following group of modules:

- Jog mode commands.
- Commands for automatic referencing.
- Positioning commands for servo drives (± 10 V and CAN bus).
- Positioning commands for rapid feed/creep feed/stop axes.
- Stop commands.
- Commands for setting and interrogating information such as the axis status.

The screenshot below shows a section of the CoDeSys library manager. This is to depict its clearly arranged structure.

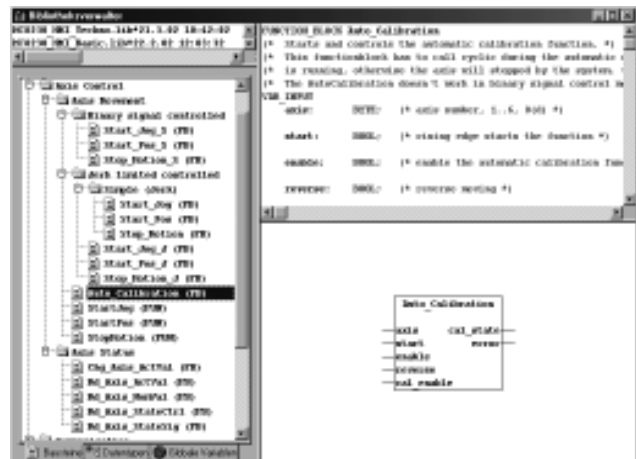

Integrated Positioning Controller	
Normal scan time	1 ms per activated axis
Ramps	Linear ramp with adjustable jerk limitation
Types of control	In binary from through the rapid feed/creep feed/stop function Clock output for stepping motor In analog from through the ± 10 V interface Ramp control In digital form through the CANopen interface
Controllable axes	6
In analog from through the ± 10 V interface and, alternatively, in binary from through the rapid feed/creep feed/stop function	3 axes
In digital from through the CANopen interface	4

Dimension GEL 8230/8231 (built-in device)

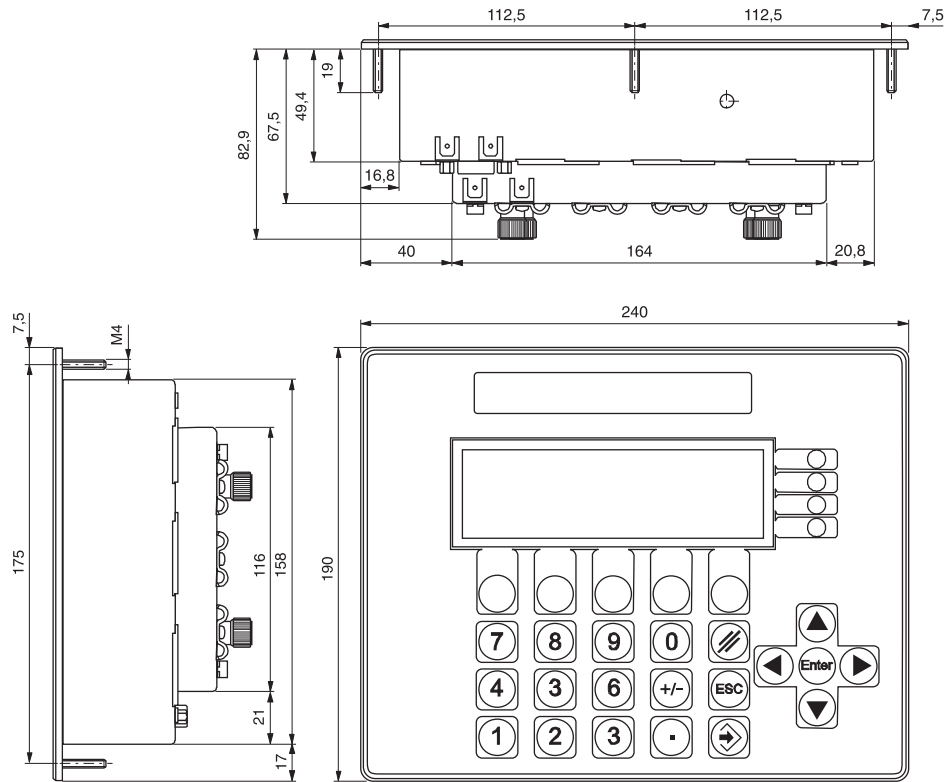

Dimension GEL 8235/8236 (top hat rail mounting)

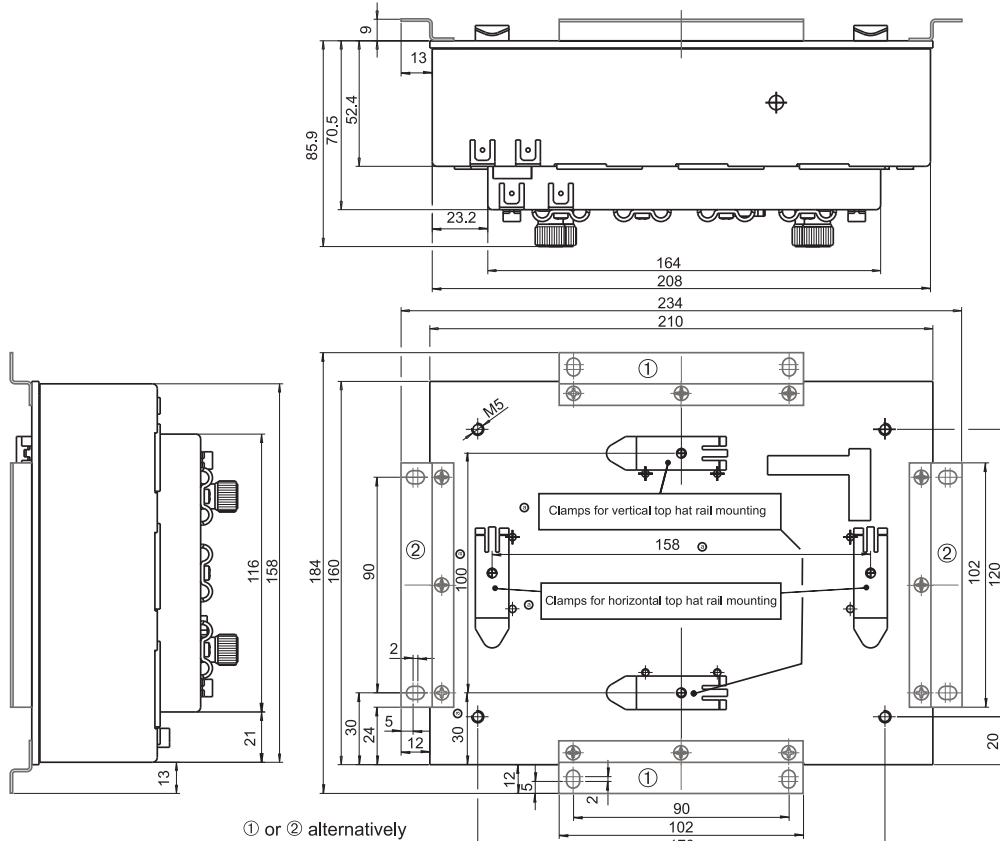

Order details

Mounting frame GK 2063 (for vertical cable outlet)

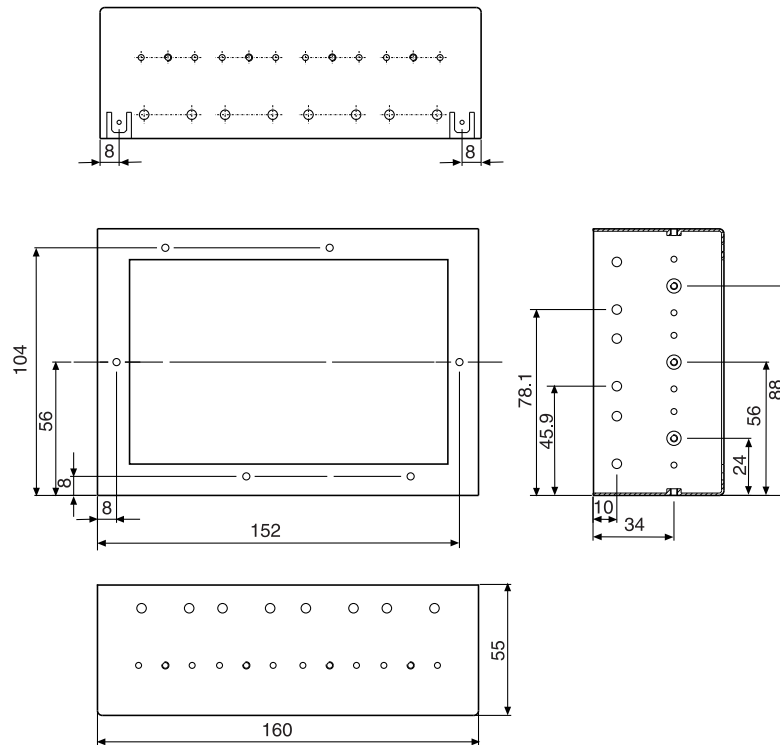

Type code

	0	LC display
	1	LC display and additional inputs
	5	no LC display for the top hat rail mounting
	6	no LC display for the top hat rail mounting and additional inputs
823	-	

Accessories (included in scope of supply)

article-no.	description	8230	8231	8235	8236
GEL 89042	counterplug set	X		X	
GEL 89043	counterplug set		X		X
BG 4622	14 hex screws M3 x 10, 14 cable bride, 2 earthing terminals, 14 toothed lock washers,	X	X	X	X
BG 4623	6 hex screws M4, 6 washer, 6 spring washers, 2 earthing terminals	X	X		
BG 4624	2 fastening brackets, 6 hex screens M3 x 6 6 spring washers, 2 earthing terminals			X	X
CD 8230	CD-ROM GEL 8230	X	X	X	X

Accessories (optional)

- GEL 89022 RS 232 C connection cable between
PC and MotionPLC
- GEL 89130 fieldbus module (PROFIBUS-DP)
- GEL 89131 fieldbus module (InterBus-S)
- GEL 89132 fieldbus module (DeviceNet)
- GK 2063 mounting frame:
6 hex screws M3 x 10
6 tooth lock washers
- DS12-823X manual GEL 823X

Subject to technical modifications and typographical errors.
For the latest version please visit our web site : www.lenord.de.