

General

With the LD2000 translatory and rotary movements can be automated in nearly all fields of application.

Description of the LogiDrive 2000:

- actual value indication either via the CAN bus or as analogue signal (0 ... ± 10 V)
- actual feedback value via the CAN bus or an incremental signal
- simple operation
- power categories from 0.5 ... 10 kW
- compact size
- suitable for 300 mm-switch cabinet
- all filters integrated
- Windows software with oscilloscope function for current and speed
- according to CE requirements and standards
- possible connection to all international voltage mains from 230 V ... 480 V + 10 %
- the open hard- and software architecture offers unrestricted possibilities of application and communication
- high cycle time (62 μ s) of current regulator
- free programming for individual drives requirements
- little internal loss
- patented switching for distribution of ballast capacities

Concept, Operation software

Concept

Operation and parameterizing

- via software LD2000
- emergency operation via two buttons directly installed at the servo amplifier and three-digit LED display for the indication of the actual status
- completely programmable via RS 232-interface

Capacities

- current supply: B6-bridge rectifier, directly installed at the three-phase earthed mains, mains filter and starting switch integrated
- connections: all shield connections directly installed at the amplifier
- power amplifier: IGBT-module with potential free current measurement
- ballast switch: with dynamic distribution of ballast capacity to several amplifiers at the same intermediate circle, external ballast resistor acc. to requirements.
- intermediate circuit voltage: 300 ... 900 V DC, parallel switching

Controlling

- freely programmable, digital current regulator (62 μ s) and freely programmable, digital speed controller (250 μ s)
- evaluation of resolver signals, respectively sine and cosine signals of a highly defined encoder
- encoder emulation

Functions

- adjustable actual value ramps
- 2 programmable, analogue monitor outputs
- 4 programmable, digital inputs and 2 programmable, digital outputs
- freely programmable connections (logic) of all digital messages

Hardware prerequisites

- processor : 80486 or higher
- operating system : Windows 95/98 and Windows NT 4.0 (not operational under Windows 3.xx)
- disk drive : 3,5"
- working memory : min. 8 MB
- interface : one free, serial interface (COM1 or COM2)

Software manual LD2000.exe

(incl. in the scope of supply)

The comfortable software operation manual LD2000 in conjunction with a PC enables modifications of the servo converter's operating parameters. The PC is connected serially to the servo converter with a null modem cable. Thus, parameters are amendable with little efforts. At the

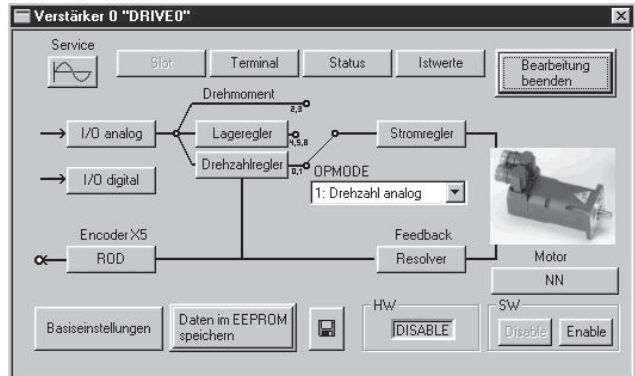

drive, the reaction is directly recognizable as a permanent connection exists.

Simultaneously, the converter supplies important actual values which are displayed by the PC (oscilloscope

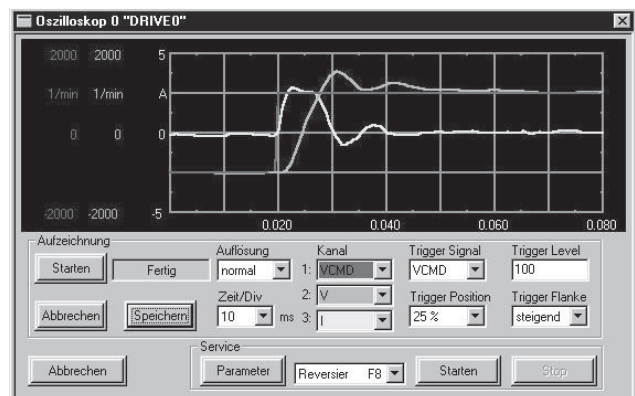

function).

Operation parameters can be stored on a data carrier and re-loaded.

LD 2000 and EcoController GEL 8100

Via the CAN Bus which is installed in the LD 2000 up to 6 servo converters may be connected to the L+B EcoController series GEL 81XX.

With this low priced drives system you will be in a position to realise simple positioning tasks as well as special applications i.e. „flying saw“, „rotating cutter“, „synchronisations“ or the L+B „EcoPLC“. L+B will also supply cables according to your requirements.

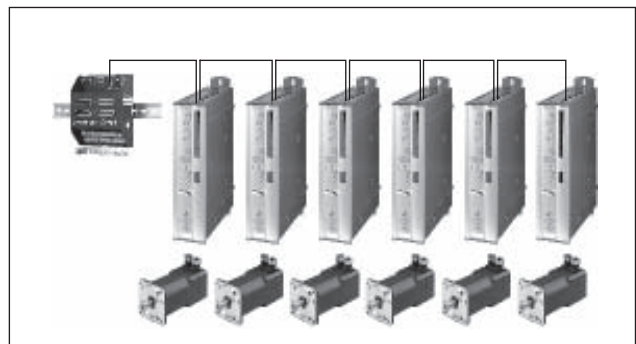

Technical data

		LogiDrive 2000					
		DIM	2001	2003	2006	2010	2020
Nominal data							
nominal connecting voltage	V~	3 x 230 _{-10%} ... 480 ^{+10%} , 50 ... 60 Hz					
nominal connecting power for S1-operation	kVA	1	2	4	7	14	
nominal output current (effective value, ± 3%)	Arms	1.5	3	6	10	20	
peak output current (max. approx. 5s, ± 3%)	Arms	3	6	12	20	40	
rest power dissipation, power amplifier disabled	W	15					
power dissipation for nominal current (incl. mains part power dissipation, without ballast-power dissipation)	W	30	40	60	90	165	
Internal safety							
auxiliary voltage 24V	internal 3.15 AT						
ballast resistor	internal electrical						
External safety							
AC-supply $F_{N1/2/3}$		6 AT		10 AT		20 AT	
24V-supply $F_{H1/2}$		max. 16 AF					
ballast resistor $F_{B1/2}$		4 AF		6 AF			
Inputs							
nominal value 1/2, resolution 14bit/12bit	V	±10					
common-mode voltage max.	V	±10					
input resistance	kΩ	20					
digital control inputs	V	low 0...7 / high 12...36					
	mA	7					
auxiliary voltage supply, potentially separated without brake	V	20 ... 36					
	A	1					
auxiliary voltage supply, potentially separated with brake	V	24 (-0% +15%)					
	A	3					
max. output current brake	A	2					
Mechanics							
weight	kg	2.5					3
measurements (HxBxT) without connector	mm	275x70x265					275x100x265
Admissible ambient conditions							
transport temperature / -air humidity (rel.)	-25 ... +70 °C, max. 20 K/h unsteady / 95%, not condensing						
storage temperature / -air humidity (rel.)	-25 ... +55 °C, max. 20 K/h unsteady / 95%, not condensing						
ambient temperature in operation	0 ... +40 °C for nominal data, +40 ... +55 °C with decrease of performance 2.5%/°C						
air humidity (rel.) in operation	85%, non condensing						
installation height	to 1000 m over msl without limit, 1000 ... 2500 m over msl with decrease of performance, 1.5%/100 m						
contamination level	2 according to EN 60204/EN 50178						
protection class	IP 20						
assembly position	generally vertical						
ventilation		free convection			integrated fan		

Connection diagram

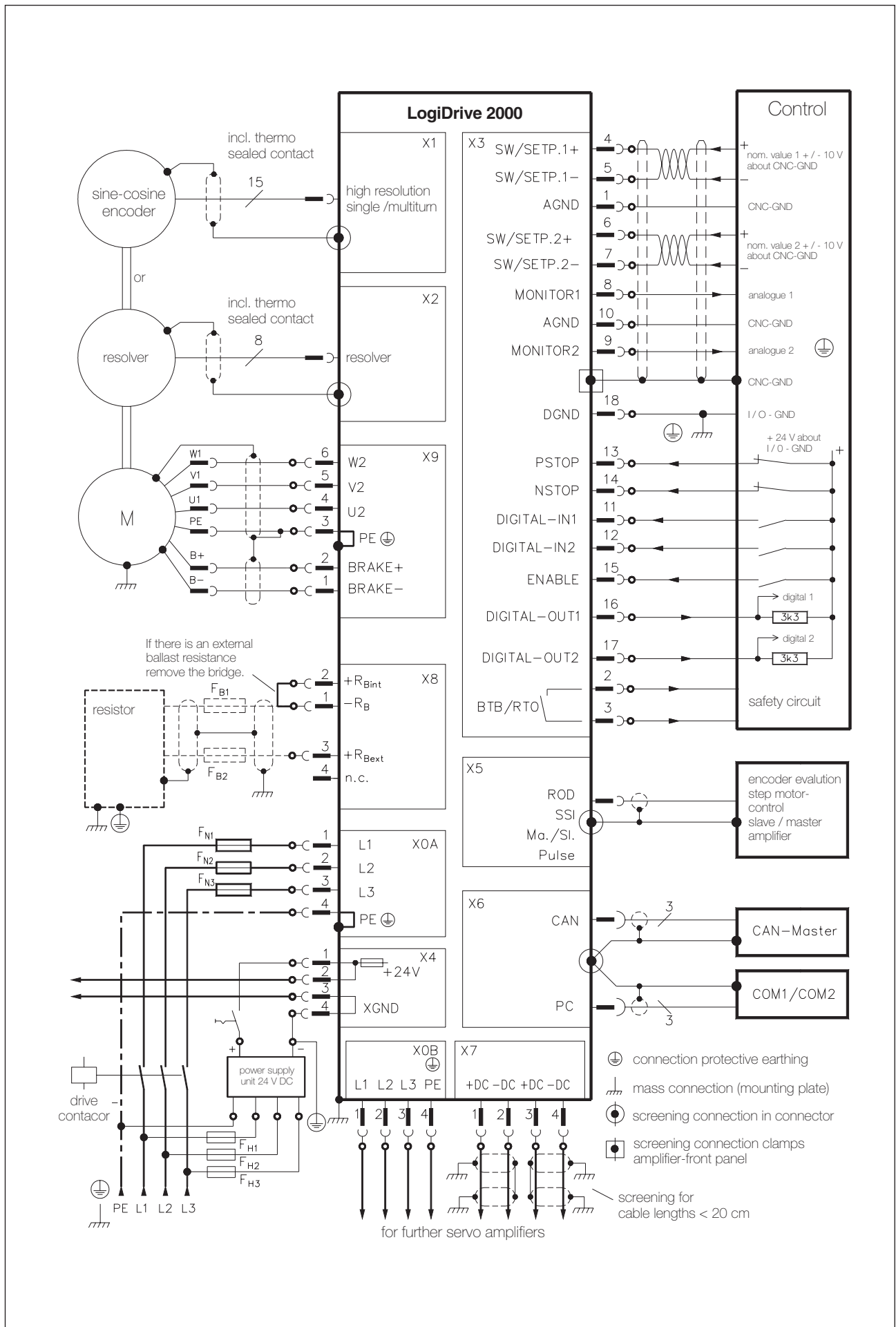

Pin layout

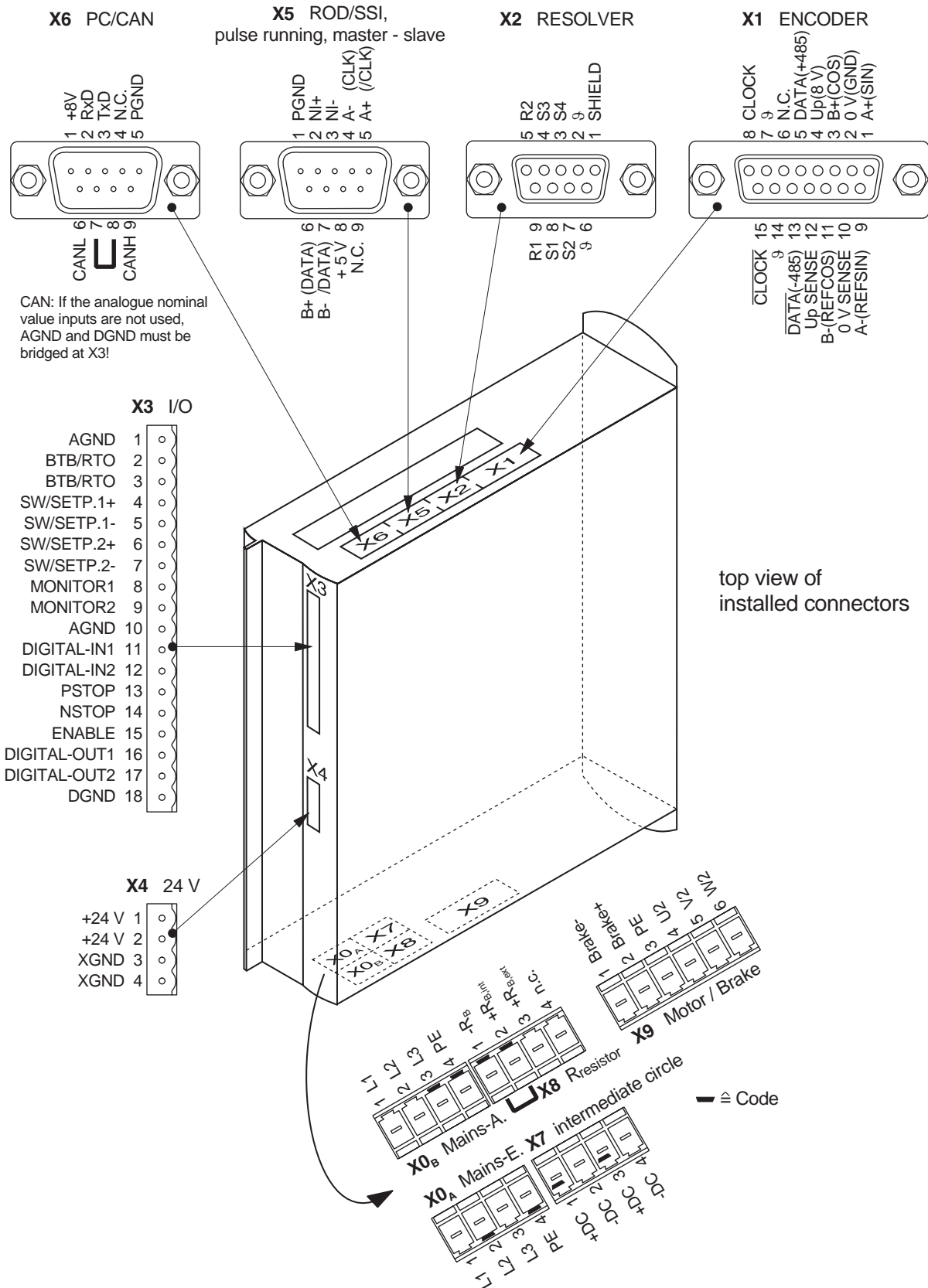

Accessories

	type	description	
Servo motors 129 ⇨	6 SM 27M-4000	Mo=0.32 Nm, Io=0,8 Arms	
	6 SM 27M-4000 G	Mo=0.32 Nm, Io=0.8 Arms	with brake
	6 SM 37S-6000	Mo=0.50 Nm, Io=1.0 Arms	
	6 SM 37S-6000 G	Mo=0.50 Nm, Io=1.0 Arms	with brake
	6 SM 37M-6000	Mo=1.00 Nm, Io=1.6 Arms	
	6 SM 37M-6000 G	Mo=1.00 Nm, Io=1.6 Arms	with brake
	6 SM 37L-4000	Mo=1.50 Nm, Io=1.6 Arms	
	6 SM 37L-4000 G	Mo=1.50 Nm, Io=1.6 Arms	with brake
	6 SM 47L-3000	Mo=3.00 Nm, Io=2.3 Arms	
	6 SM 47L-3000 G	Mo=3.00 Nm, Io=2.3 Arms	with brake
	6 SM 57S-3000	Mo=4.60 Nm, Io=2.8 Arms	
	6 SM 57S-3000 G	Mo=4.60 Nm, Io=2.8 Arms	with brake
	6 SM 57M-3000	Mo=8.00 Nm, Io=4.3 Arms	
	6 SM 57M-3000 G	Mo=8.00 Nm, Io=4.3 Arms	with brake
	6 SM 77K-3000	Mo=11.00 Nm, Io=6.0 Arms	
	6 SM 77K-3000 G	Mo=11.00 Nm, Io=6.0 Arms	with brake
	6 SM 77S-3000	Mo=17.00 Nm, Io=10.0 Arms	
	6 SM 77S-3000 G	Mo=17.00 Nm, Io=10.0 Arms	with brake
	6 SM 107K-3000	Mo=26.00 Nm, Io=17.0 Arms	
	6 SM 107K-3000 G	Mo=26.00 Nm, Io=17.0 Arms	with brake
6 SM 107S-3000	Mo=32.00 Nm, Io=21.4 Arms		
6 SM 107S-3000 G	Mo=32.00 Nm, Io=21.4 Arms	with brake	

Type code motor cable

KM 129	X	X	XXX	description
			002	length e. g. for 2 m
			A	cross section 1.0 mm ²
			B	1.5 mm ²
			C	2.5 mm ²
			D	0.25 mm ²
			M	cable type motor cable
			B	motor cable incl. wires for the brake
			R	resolver cable

	type	description	
Accessories ⇒ ballast resistor 33 Ohm	BW 121.1	BAR 250 W	
	BW 121.2	BAR 500 W	
	BW 121.3	BAR 1500 W	
motor choke for motor cables > 25 m	MD 121.1	3YL-06, choke for Logidrive LD 200600	
	MD 121.2	3YL-10, choke for Logidrive LD 201000	
	MD 121.3	3YL-20, choke for Logidrive LD 202000	
screen connection clamps	SK 121.1	SR6SKL1, 6-7 mm	
	SK 121.2	SR6SKL2, 8-9 mm	
	SK 121.3	SR6SKL3, 10-11 mm	
connection line	AA 121.1	adapter for LD 2000, for simultaneous use of RS 232- and CAN bus interface to connector X6	
	AL 121.9	connection line PC-LD2000, 9-pole PC-plug, 3 m	
	AL 121.25	connection line PC-LD2000, 25-pole PC-plug, 3 m	
	ALC 121.1	connection line EcoController with 1 converter, 2 m	
	ALC 121.2	connection line EcoController with 2 converters, 2 m / 0.2 m	
	ALC 121.3	connection line EcoController with 3 converters, 2 m / 0.2 m	
	ALC 121.4	connection line EcoController with 4 converters, 2 m / 0.2 m	
	ALC 121.5	connection line EcoController with 5 converters, 2 m / 0.2 m	
	ALC 121.6	connection line EcoController with 6 converters, 2 m / 0.2 m	
			further lengths upon request
connector (motor)	LS 129-L2	motor connector	
	SS 129-L2	resolver connector	
connector (converter)	GG 121.0	counterplug a. c. mains (X0)	
	GG 121.3	counterplug I/O (X3)	
	GG 121.4	counterplug 24 V (X4)	
	GG 121.7	counterplug intermediate circle (X7)	
	GG 121.8	counterplug ballast resistor (X8)	
	GG 121.9	counterplug motor (X9), kit	
	GG 121.10	9-pole sub-D-counterplug PC/CAN (X6); female	
	GG 121.11	9-pole sub-D-counterplug incr./SSI (X5); female	
	GG 121.12	9-pole sub-D-counterplug resolver (X2); pin	
	GG 121.13	15-pole sub-D-counterplug sin-cos-encoder (X1); pin	

The counterplugs GG 121.0, GG 121.3, GG 121.4, GG 121.7, GG 121.8 are included in the scope of supply.

The following items are not included in the scope of supply (please order separately):

- the sub-D-counterplug
- servo motor 6 SM
- motor line (ready for use), or both motor connectors LS 129-L2 and GG 121.9 separately with motor line by the metre
- resolver line (ready for use), or both resolver connectors SS 129-L2 and GG 121.12 separately with resolver line by the metre
- motor choke (for line length of more than 25 m)
- external ballast resistor
- communication line for the PC or adapter for parameterizing a servo-amplifier at a PC
- CAN bus-line EcoController-LD2000

Dimensioned drawing, Type code



Dimensioned drawing

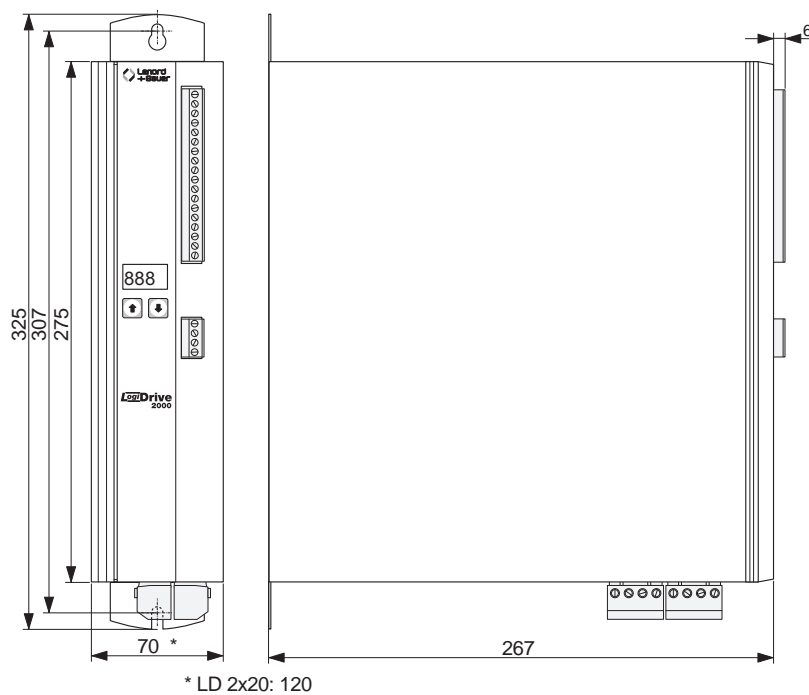

* LD 2x20: 120

Type code LD2000

LD 2	X	XX	0	0	description
					nominal current output
			01		1.5 A
			03		3 A
			06		6 A
			10		10 A
			20		20 A
					insert card
			0		without

This information is supplied without liability.
Printing and other errors excepted.