



↔ GEL 212



GEL 213 ↔

General Information

- conversion of standardized sine signals into square signals up to an interpolation factor of 512

Range of application

- interpolation of sine signals from the MiniCoder GEL 2442 K/KM/KN, GEL 243 L, GEL 295 K/KN
- interpolation of sine-shaped voltages with an amplitude of $1 V_{PP}$

Input Signals

- two sine-wave signals offset by 90° and their inverse signals
- signal level $250 mV_s$ peak value, per track = $1 V_{PP}$ as differential signal
- reference signal and inverse reference signal (option)

Output Signals

- two square-wave signals offset by 90° and their inverse signals
- reference pulse (option)
- output either with 5 V DC or 0 ... 30 V DC signal level
- with quadruple edge evaluation you can achieve a resolution of up to 2048 pulses per input signal cycle

Design

- GEL 212: 12-pole circular connector, IP 65
- GEL 213: terminal strip, IP 20

Technical data

supply voltage U_B	10 ... 30 V DC (V, X, U), 5 V DC (T)
power consumption without load	≤ 1 W
output level T-signal	high level: $\geq U_B - 1.00$ V if $I = 10$ mA; $\geq U_B - 1.20$ V if $I = 30$ mA low level: ≤ 0.75 V if $I = 10$ mA; ≤ 1.00 V if $I = 30$ mA
output level U-signal	high level: ≥ 4 V if $I = 10$ mA; ≥ 3.85 V if $I = 30$ mA low level: ≤ 0.75 V if $I = 10$ mA; ≤ 1.00 V if $I = 30$ mA
output level V-, X-signal	high level: $\geq U_B - 1.80$ V DC if $I = 10$ mA; $\geq U_B - 2.20$ V DC if $I = 30$ mA low level: ≤ 1.15 V DC if $I = 10$ mA; ≤ 1.55 V DC if $I = 30$ mA
input tracks	two square-wave signals offset by 90° and their inverse signals (option)
outputs (T, TN, U)	TTL-, RS 422- and RS 485-compatible
outputs (V, X)	push-pull signal
input tracks	sine/cosine signals and their inverse signals with differential voltage $1V_{pp}$, optional: reference signal (N)
outputs frequency ≤ 200 kHz	input frequency by multiplier (max. 200 kHz) available with multiplier 1, 2, 4, 8, 10, 16, 20, 25, 32, 40, 50, 64, 80, 100, 125, 128, 200, 256, 400, 500 or 512
input frequency	0 ... 50 kHz
short-wave precision (referring to a toothed wheel with 256 teeth module = 0.3)	$0,08^\circ$, pairing of sensor and interpolations electronic
long-wave precision	dependent on the precision of the measuring scale
max. admissible cable length between the sensor and the interpolation electronics	25 m if the cable cross section is 0.5 mm ²
operating temperature range	-40°C ... 85°C
protection class	GEL 212: IP 65 GEL 213: IP 20
electromagnetic compatibility	EN 61000-6-1 to 4
insulation strength	500 V
vibration protection (EN 50155)	20 g m/s ²
connectors	GEL 212: 12-pole circular connector GEL 213: terminal strip

Dimensioned drawing

Dimensioned drawings GEL 212

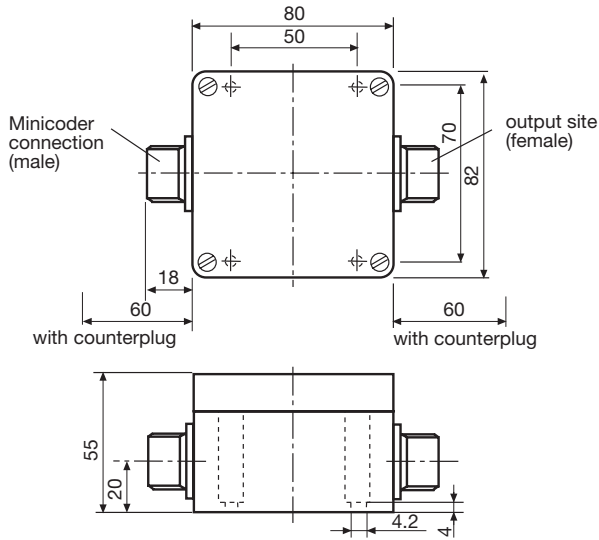

Dimensioned drawings GEL 213

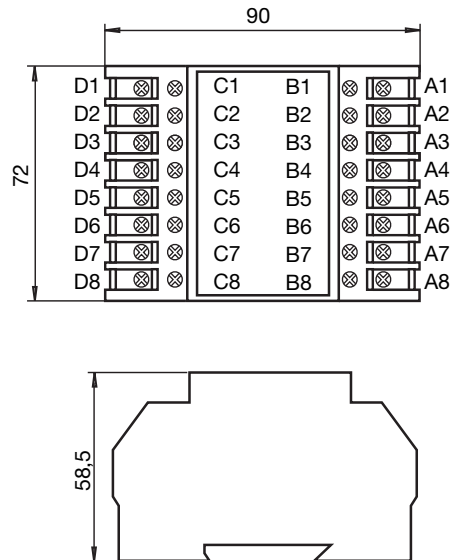

Pin layout GEL 212 and GEL 213

GEL 212

GEL 213

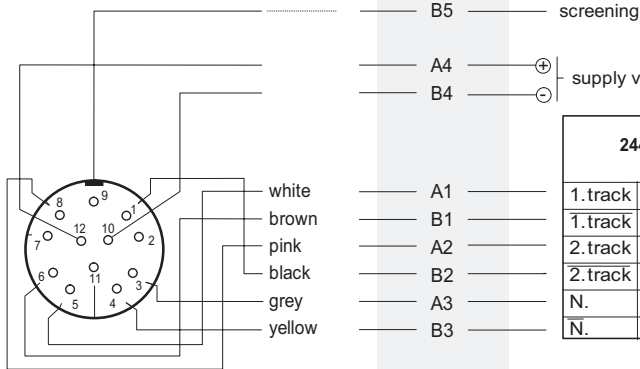

Connection type:

GEL 212 12-pole circular connector

GEL 213 terminal strip

	2442	2442 K	2442 KM, KN	243	243 L
1. track	0.5 V _{PP}			1. track	1 V _{PP}
1. track	0.5 V _{PP}			BZ *	U _B / 2
2. track	0.5 V _{PP}			2. track	1 V _{PP}
2. track	0.5 V _{PP}			BZ *	U _B / 2
N.					
N.					

clockwise rotation

BZ * = reference potential

GEL 212 Output site (12-pole connector, male)

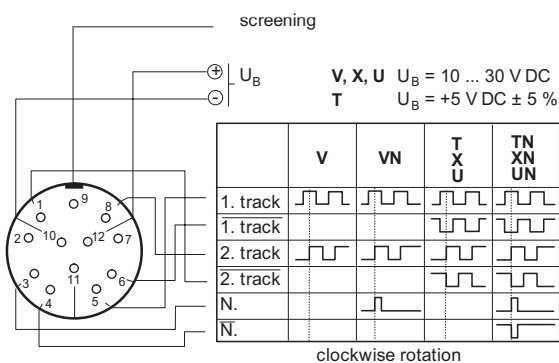

GEL 213 Output site (terminal strip)

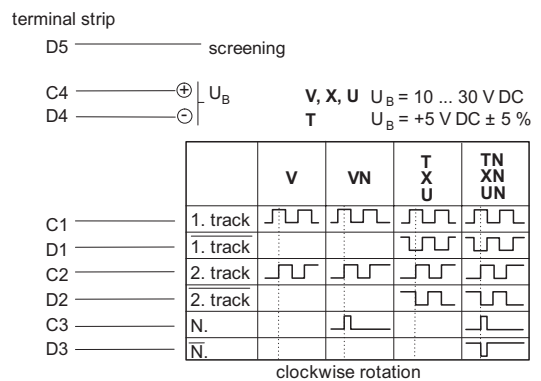

Type code GEL 212/213

2 3	design (see page 1)		
	T- TN V- VN U- UN X- XN	signal pattern signal pattern and supply voltage (see page 2)	
		multiplier	
		01	interpolation factor 1
02	interpolation factor 2		
04	interpolation factor 4		
08	interpolation factor 8		
10	interpolation factor 10		
16	interpolation factor 16		
20	interpolation factor 20		
25	interpolation factor 25		
32	interpolation factor 32		
40	interpolation factor 40		
50	interpolation factor 50		
64	interpolation factor 64		
80	interpolation factor 80		
AA	interpolation factor 100		
BB	interpolation factor 125		
CC	interpolation factor 128		
DD	interpolation factor 200		
EE	interpolation factor 250		
FF	interpolation factor 256		
GG	interpolation factor 400		
HH	interpolation factor 500		
KK	interpolation factor 512		
	sense control		
	0	without	
21	-	-	0



Note:

When using the GEL 212 or GEL 213 Interpolation Electronics in combination with a GEL 243 or GEL 2442 sensor or with a GEL 295 encoder the components are factory-adapted to each other (the Interpolation Electronics has been labelled with the serial number of the sensor/encoder belonging to it). Sensors from other manufacturers are to be adapted to the Interpolation Electronics in the factory.