

GEL 260

Magnetic measuring system, high resolution,
also suitable for use in explosion-hazardous areas

Technical information

version 12.08



GEL 260



GEL 260 EEx

Incremental encoders convert rotations into electric signals. The Lenord + Bauer encoders combine the advantages of a magnetic measuring system and a robust mechanical design. They have proven successful all over the world in many different applications and even under roughest industrial conditions. Their high reliability and a long service life go without saying.

Fields of application

- Heavy industry
- Paper-making and packaging machines
- Filling machines
- Transporting and storing systems
- Machines for processing steel, wood, stone, textiles and plastic, etc.

Main characteristics

- High resolution up to 273.408 pulses per revolution
- Interpolation up to 1024
- Additionally current output
0 ... 20 mA, 4 ... 20 mA, -20 ... +20 mA (option)
- Reference signal
- Cable or plug outlet, axial or radial
- High electromagnetic compatibility (EMC)
- For use in explosion hazardous areas (option)

Measuring principle

The encoders work with differential sensors depending on magnetic fields and a precision toothed wheel as measure. The sensors scan the tooth structure of the toothed wheel and emit a sine or cosine voltage. The integrated evaluation electronics in ASIC and SMD technology converts the analogue sensor signals into incremental output signals.

Advantages of the magnetic system

- No adverse effect due to condensed water
- Absolute operational reliability even in case of high humidity (dewing) and frequent change of ambient temperature
- Extremely insensitive to dirt, oil and water
- Extremely shock- and vibration-resistant because the measure is not made of glass nor plastic
- Outstanding operational safety over a very long period of time as it does not suffer from ageing effects as optical systems do

Output signals

Signal pattern V, VN

Signal pattern "V" stands for two tracks with square-wave signals, offset by 90° (push-pull output). With each revolution, a reference signal with defined length is put out on the third track N (optionally).

At an output frequency of 200 kHz the edge distance (F) is $\geq 0.6 \mu\text{s}$.

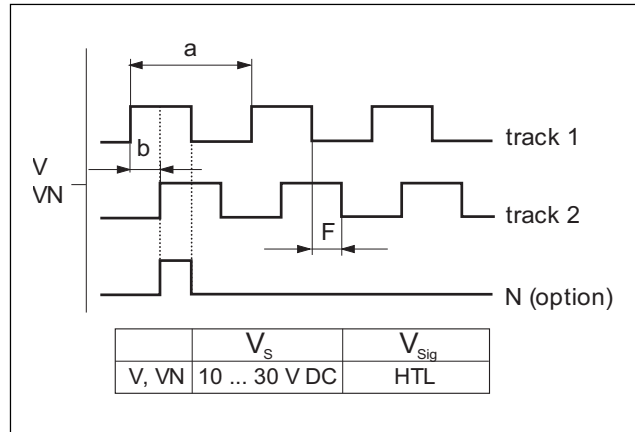

Signal pattern T, TN, U, UN, X, XN

Both tracks and the reference signal (option) are additionally output as inverse signals.

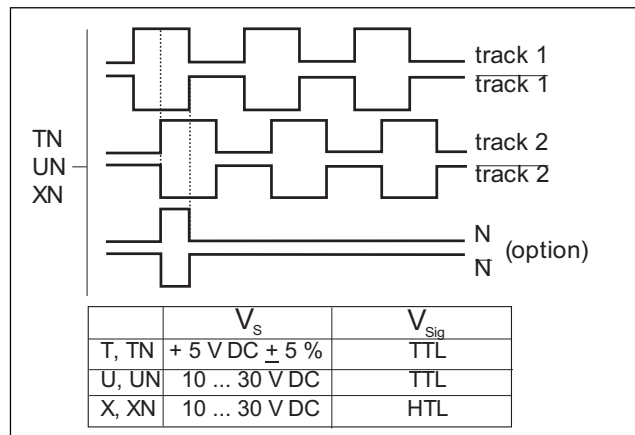

Signal pattern S, SN

Pulses which are independent of the rotational direction and the duration of which is constant are derived from the square-wave signals as per signal pattern V and put out on track 2. Furthermore, a signal depending on the rotational direction is obtained from the signal pattern which is put on track 1.

Once per each revolution a reference signal is output on the third track N (optional). The outputs have a final push-pull power stage. All outputs are sustained short-circuit-proof. The pulses follow a possible change of rotation with a slight delay, in order that a subsequent counter setting can be adjusted to the counting direction prior to the pulse. The sense-dependent signal may be reversed via a which is accessible from outside (switch 1).

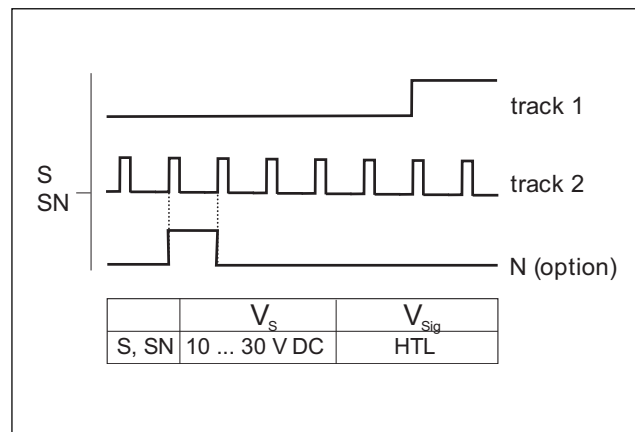

Key

- V_s = operating voltage
- V_{Sig} = signal voltage
- a = 360° electrical
- b = 90° phase shift
- F = edge distance (for an output frequency of 200 kHz the edge distance is $F \geq 0.6 \mu\text{s}$)

Signal pattern = shown for clockwise rotation (view on top of the encoder shaft)

Reference signals with other lengths upon request.

Output level

The signal patterns S, SN, V, VN, X and XN have HTL level, the signal patterns T, TN, U and UN have TTL level (for the output voltage see electrical data).

All outputs have a push-pull power amplifier and are short-circuit-proof. The peak output current for recharging the cable capacity is 100 mA.

Various current outputs

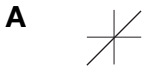

Measuring current which is independent on the sense of rotation and which has a nominal range of -20 ... +20 mA. The polarity of the current can be reversed by switch 1 which is accessible from outside.

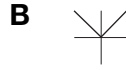

Measuring current which is independent of the sense of rotation and which has a nominal range of 0 ... +20 mA.

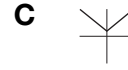

Measuring current which is independent of the sense of rotation and which has a nominal range of +4 ... +20 mA.



The switch position deviates from the one of the previous model, i. e. GEL 262. If the device is preset in the factory and in case of clockwise rotation the specified signals are valid.

Current output

For the means of displaying and controlling, a measuring current of 0 to 20 mA, 4 to 20 mA or -20 to +20 mA can be obtained from the pulse frequency which depends on the speed and – if ordered – the sense of rotation. For this purpose the measuring pulses are integrated and converted into a rotation speed dependent output current.

There is a strictly linear interrelation between the measuring current and the pulse frequency.

Because of the high resolution (up to 273,408 pulses per revolution) a DC

output current is obtained which shows a low harmonic content even at a very low speed range (e.g. 0 to 0.5 min⁻¹). The harmonic content depends on the pulse frequency and the determined attenuation *d*, latter influencing the rising and trailing edge times as well as the delay time in case of erratic changes of the speed.

The preferred attenuation had been specified when ordering the encoder corresponding to the following diagram; *d*₃ is the default setting.

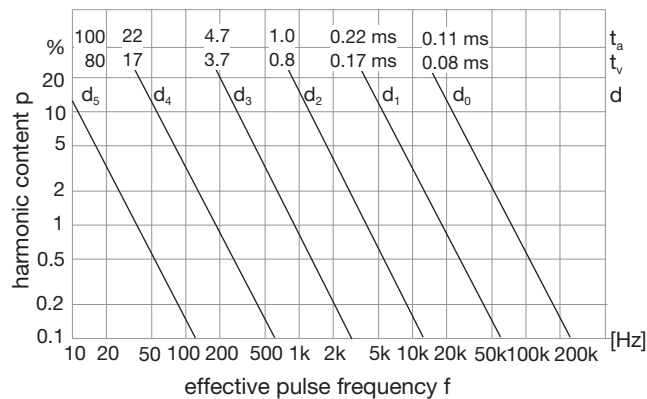

*t*_a = rise time
*t*_v = delay time
d = attenuation

*t*_a, *t*_v = *f* (*d*)
p = *I*_{eff} / *I*_a
f = *n* · *i* [Hz]

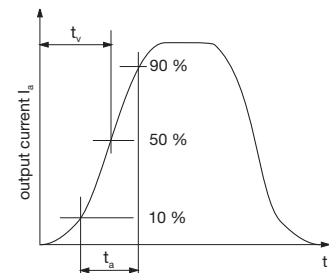

Data of the current outputs

| | | | | |
|--------------------------------|--------------------------|---|----------------------------------|---------|
| max. apparent ohmic resistance | <i>R</i> _a | | 550 | Ω |
| measuring device class | K | | 1 | |
| rated current tolerance | | | < 1 | % |
| linearity error | | | < 1 | % |
| repeatability | <i>r</i> | | 100 | % |
| temperature drift | Δ <i>I</i> _{aT} | | < ± 3 | μA/1 °K |
| min. RPM | <i>n</i> _{min} | electrical (attenuation <i>d</i> ₅) | 1.5 × 10 ³ / <i>i</i> | RPM |
| max. RPM | <i>n</i> _{max} | electrical | 6 × 10 ⁶ / <i>i</i> | RPM |

i = rated pulse number

Technical data according DIN 32878

| Description | | GEL 260 | GEL 260 EEx |
|---|--|---|--|
| measuring step from ... to ¹⁾ | | 36 ... 0.013° | |
| pulse number per revolution ¹⁾ | | 10 ... 273.408 | |
| accuracy | error limit ²⁾ | 0.07° | |
| | incremental deviation ²⁾ | 0.01° | |
| | repeatability ²⁾ | 0.005° | |
| electrical data | power consumption $R_L = \infty, V_S = 10...30 \text{ V DC}$ $R_L = \infty, V_S = 5 \text{ V DC}$ | ≤ 1.3 W (with current output: ≤ 1.65) ≤ 1.0 W (with current output: ≤ 1.40) | |
| | max. output frequency | | |
| | output level for signal pattern T/TN (logic level TTL) | high signal: ≥ $V_S - 1.00 \text{ V}$ at $I = 10 \text{ mA}$; low signal: ≤ 0.75 V at $I = 10 \text{ mA}$; | ≥ $V_S - 1.20 \text{ V}$ at $I = 30 \text{ mA}$ ≤ 1.00 V at $I = 30 \text{ mA}$ |
| | output level for signal pattern U/UN (logic level TTL) | high signal: ≥ 4.00 V at $I = 10 \text{ mA}$; low signal: ≤ 0.75 V at $I = 10 \text{ mA}$; | ≥ 3.85 V at $I = 30 \text{ mA}$ ≤ 1.00 V at $I = 30 \text{ mA}$ |
| | output level for signal pattern S/SN, V/VN and X/XN (logic level HTL) | high signal: ≥ $V_S - 1.80 \text{ V}$ at $I = 10 \text{ mA}$; low signal: ≤ 1.15 V at $I = 10 \text{ mA}$; | ≥ $V_S - 2.20 \text{ V}$ at $I = 30 \text{ mA}$ ≤ 1.55 V at $I = 30 \text{ mA}$ |
| mechanical data | shaft diameter | 6 mm, 8 mm, 10 mm, 12 mm | |
| | housing diameter | 90 mm | 115 mm |
| | weight | approx. 0.7 kg | approx. 5.1 kg |
| | max. operating | 10,000 min ⁻¹ | 3,000 min ⁻¹ |
| | moment of inertia of rotor | 7 · 10 ⁻⁵ kgm ² | |
| | max. angular acceleration | extremely high, as shaft and measuring wheel (steel) are pressed | |
| | operating torque | 0.03 Nm (< 0.01 Nm with ball bearing cover (IP 50) Option) | |
| | starting torque | 0.05 Nm (0.01 Nm with ball bearing cover (IP 50) Option) | |
| | max. shaft load (point of application 15 mm before the contact surface of the flange) | 200 N axial 200 N radial | |
| | permissible shaft load | We recommend connection by a radial flexible coupling. | |
| | bearing life (at half shaft load) | 12.600 · 10 ⁶ revolutions | |
| | bearing life (at max. shaft load) | 2.000 · 10 ⁶ revolutions | |
| environmental conditions | operating temperature | 0 ... + 70 °C (standard); - 20 ... +85 °C (option) | |
| | ambient temperature | - 20 ... + 85 °C | |
| | storage temperature | -40 ... +105 °C | |
| | protection class according to DIN EN 60529 | IP 65 | pressure-resistant IP 54 |
| | vibration protection (option) according to DIN EN 60068-2-6 | frequency 10 ... 2000 Hz; peak acceleration 100 m/s ² ; frequency cycles 10 | |
| | shock protection (option) according to DIN EN 60068-2-27 | peak acceleration 1000 m/s ² ; duration 11 ms | |
| | insulation strength according to VDE 0660 part 500 version 08/00 or DIN EN 60439-1 | $R_i > 1 \text{ M}\Omega$, at a testing voltage of 500 V AC | |
| | electromagnetic compatibility | EN 61000-6-1 to 4 | |

¹⁾ max. value with external evaluation of the signal pattern. See page 7 for possible pulse numbers (resolutions).

²⁾ value for highest resolutions. Values for low resolutions on request.

Pin layouts: plug, Cable assignment

Pin layout: plug

(The counter plug is included in the scope of supply.)

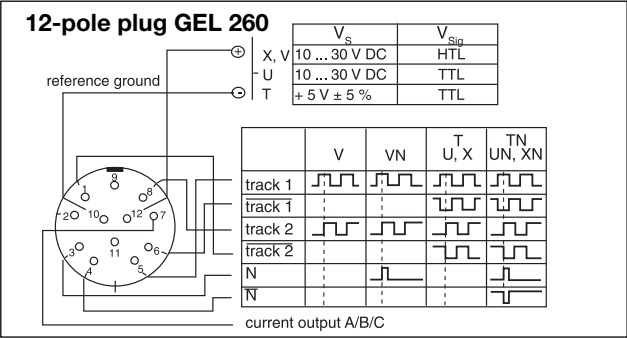
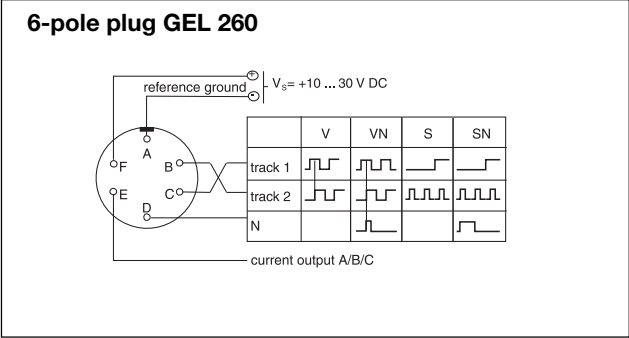

Cable assignment

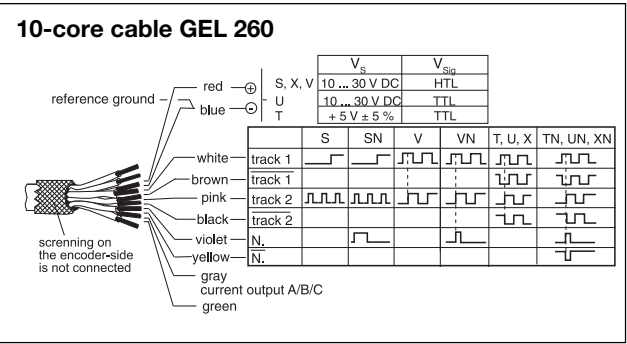
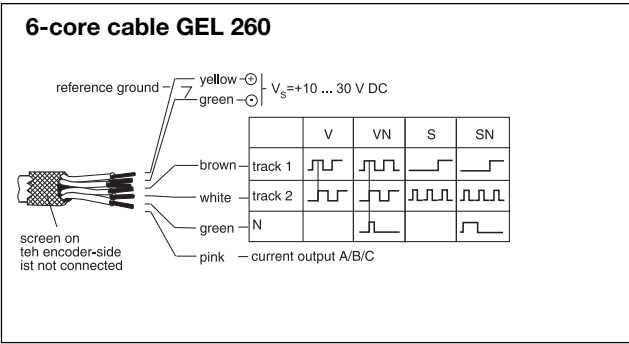

Cable assignment

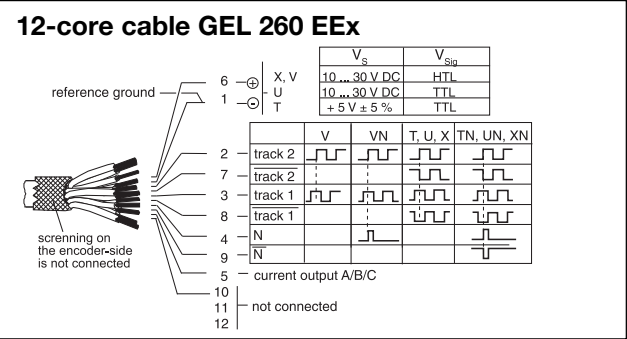
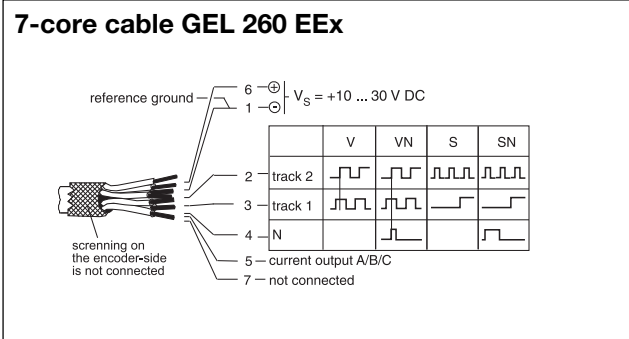

Key

V_s = operating voltage
 V_{Sig} = signal voltage
 current output A = -20 mA ... +20 mA
 current output B = 0 mA ... +20 mA
 current output C = +4 mA ... +20 mA
 Signal pattern shown for clockwise rotation (view on top of the encoder shaft). Reference signal with other length upon the request.

Maximum Cable Lengths

between encoder and secondary electronics. The cable screening is to be earthed one-sided at the receiver. The stated data are standard values referring to cable type LiYCY 6 (10) x 0,25 mm².

| $V_s = 5\text{ V (TN, UN), sense connected}$ | | | | | | |
|--|-----|-----|-----|-----|-----|-----|
| f [kHz] | 5 | 10 | 20 | 50 | 100 | 200 |
| L_{max} [m] | 200 | 200 | 200 | 200 | 145 | 72 |

| $V_s = 20\text{ V (SN, VN)}$ | | | | | | |
|------------------------------|-----|-----|-----|----|-----|-----|
| f [kHz] | 5 | 10 | 20 | 50 | 100 | 200 |
| L_{max} [m] | 200 | 200 | 200 | 80 | 40 | 20 |

| $V_s = 20\text{ V (XN)}$ | | | | | | |
|--------------------------|-----|-----|-----|----|-----|-----|
| f [kHz] | 5 | 10 | 20 | 50 | 100 | 200 |
| L_{max} [m] | 200 | 200 | 100 | 40 | 20 | 10 |

Dimensioned drawings, version EEx Protection of the electronic (optional),

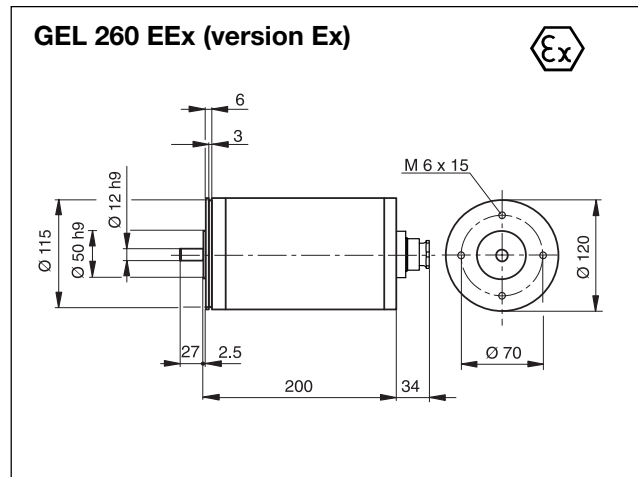
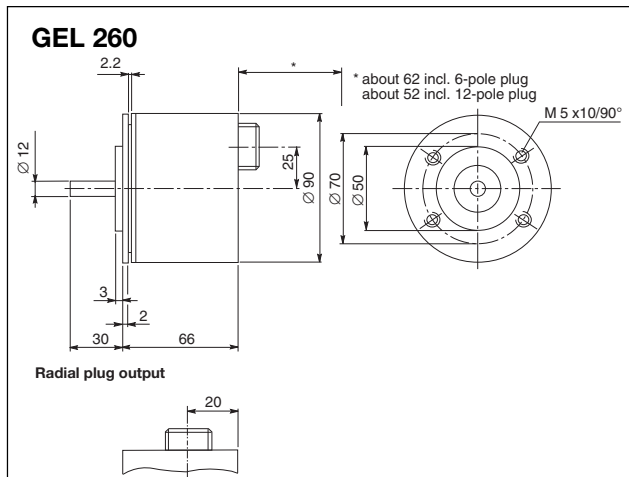

Protection of the electronics (optional)

Protection against humidity

The encoders' electronic unit is coated with a highly effective protection against humidity, salt-water atmosphere and corrosive vapours to ensure their proper functioning during years even under roughest conditions.

Condensed-water outlet

Water may accumulate in the encoder if it is exposed to multiple dewing. The water can drain off through the condensed-water outlet. When mounting the encoder the outlet must show downward. The protection class drops to IP 64.

Protection against vibration

The additional fixing of mechanical parts with special plastic prevents the electronics and the connections inside the encoder from vibrating. Thus the proper and continuous operation of the encoder - even if exposed to extreme vibration and shock - is guaranteed.

Version GEL 260 EEx

Through mounting of the GEL 260 in a flameproof housing Ex-protection to VDE 0171.

protection

class : Ex II 2G EEx de [ia/ib] IIC T5-T6

certificate : PTB03ATEX1051
(formerly PTB-Nr. Ex-87/1095)

ordering details : in the type code

protection of the electronics

-protection class EEx select -

shaft diameter, length

- $\varnothing = 12 \text{ mm}$ $L = 27 \text{ mm}$ select -

Cable outlet

- 7-core cable select -
or 12-core cable select -

GEL 260 EEx standard cable length: 1 metre. Please state in your order, if you wish other cable lengths.

Dimensioned drawing: counter plugs

(GG 66 or GG 126 are included in the scope of supply, if you wish the optional GW 66 type please state in your order.)

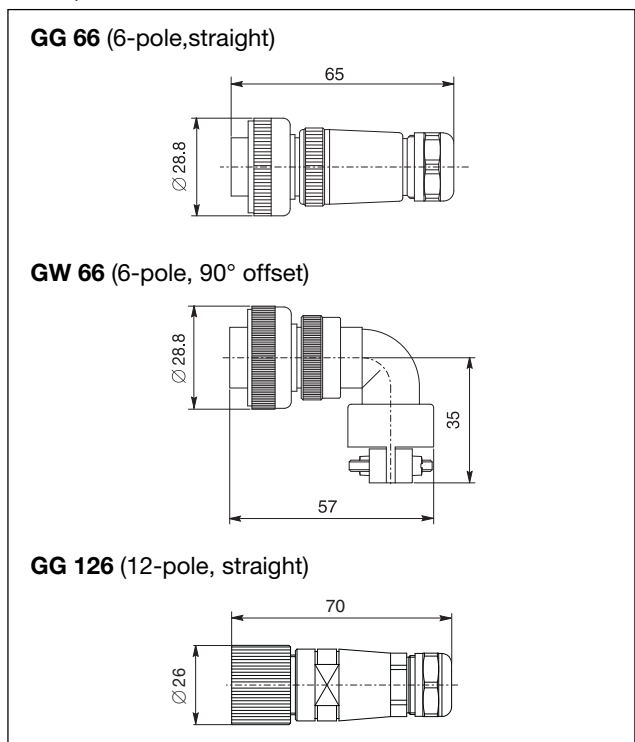
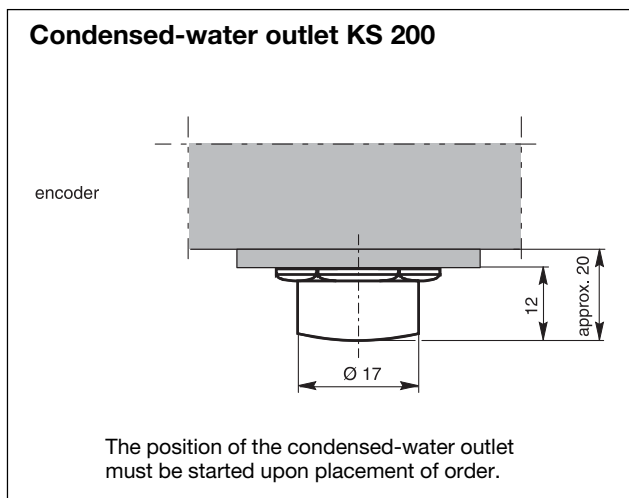

Possible pulse numbers GEL 260

| | | | | | | | | | | | | | | | | | |
|------------|-------------|-------------|------------|------------|-------------|------------|-------------|------------|-------------|------------|------|-------------|-------------|------------|-------------|------------|-------------|
| 10 | 11 | 12 | 13 | 14 | 15 | 16 | 17 | 18 | 19 | 20 | 21 | 22 | 23 | 24 | 25 | 26 | 27 |
| 28 | 29 | 30 | 31 | 32 | 33 | 34 | 35 | 36 | 37 | 38 | 39 | 40 | 41 | 42 | 43 | 44 | 45 |
| 46 | 47 | 48 | 49 | 50 | 51 | 52 | 53 | 54 | 55 | 56 | 57 | 58 | 59 | 60 | 61 | 62 | 63 |
| 64 | 65 | 66 | 67 | 68 | 69 | 70 | 71 | 72 | 73 | 74 | 75 | 76 | 77 | 78 | 79 | 80 | 81 |
| 82 | 83 | 84 | 85 | 86 | 87 | 88 | 89 | 90 | 91 | 92 | 93 | 94 | 95 | 96 | 97 | 98 | 99 |
| 100 | 101 | 102 | 103 | 104 | 105 | 106 | 107 | 108 | 109 | 110 | 111 | 112 | 113 | 114 | 115 | 116 | 117 |
| 118 | 119 | 120 | 121 | 122 | 123 | 124 | 125 | 126 | 127 | 128 | 129 | 130 | 131 | 132 | 133 | 134 | 135 |
| 136 | 137 | 138 | 139 | 140 | 141 | 142 | 143 | 144 | 145 | 146 | 147 | 148 | 149 | 150 | 151 | 152 | 153 |
| 154 | 155 | 156 | 157 | 158 | 159 | 160 | 161 | 162 | 163 | 164 | 165 | 166 | 167 | 168 | 169 | 170 | 171 |
| 172 | 173 | 174 | 175 | 176 | 177 | 178 | 179 | 180 | 181 | 182 | 183 | 184 | 185 | 186 | 187 | 188 | 189 |
| 190 | 191 | 192 | 193 | 194 | 195 | 196 | 197 | 198 | 199 | 200 | 201 | 202 | 203 | 204 | 205 | 206 | 207 |
| 208 | 209 | 210 | 211 | 212 | 213 | 214 | 215 | 216 | 217 | 218 | 219 | 220 | 221 | 222 | 223 | 224 | 225 |
| 226 | 227 | 228 | 229 | 230 | 231 | 232 | 233 | 234 | 235 | 236 | 237 | 238 | 239 | 240 | 241 | 242 | 243 |
| 244 | 245 | 246 | 247 | 248 | 249 | 250 | 251 | 252 | 253 | 254 | 255 | 256 | 257 | 258 | 259 | 260 | 261 |
| 262 | 263 | 264 | 265 | 266 | 267 | 268 | 269 | 270 | 272 | 274 | 276 | 278 | 280 | 282 | 284 | 286 | 288 |
| 290 | 292 | 294 | 298 | 300 | 302 | 304 | 306 | 308 | 310 | 312 | 314 | 316 | 318 | 320 | 322 | 324 | 326 |
| 328 | 330 | 332 | 334 | 336 | 338 | 340 | 342 | 344 | 346 | 348 | 350 | 352 | 354 | 356 | 358 | 360 | 362 |
| 364 | 366 | 368 | 370 | 372 | 374 | 376 | 378 | 380 | 382 | 384 | 386 | 388 | 390 | 392 | 394 | 396 | 398 |
| 400 | 402 | 404 | 406 | 408 | 410 | 412 | 414 | 416 | 418 | 420 | 422 | 424 | 426 | 428 | 430 | 432 | 434 |
| 436 | 438 | 440 | 442 | 444 | 446 | 448 | 450 | 452 | 454 | 456 | 458 | 460 | 462 | 464 | 466 | 468 | 470 |
| 472 | 474 | 476 | 478 | 480 | 482 | 484 | 486 | 488 | 490 | 492 | 494 | 496 | 498 | 500 | 502 | 504 | 506 |
| 508 | 510 | 512 | 514 | 516 | 518 | 520 | 522 | 524 | 526 | 528 | 530 | 532 | 534 | 536 | 540 | 544 | 548 |
| 550 | 552 | 556 | 560 | 564 | 568 | 570 | 572 | 576 | 580 | 584 | 588 | 590 | 592 | 596 | 600 | 604 | 608 |
| 610 | 612 | 616 | 620 | 624 | 628 | 630 | 632 | 636 | 640 | 644 | 648 | 650 | 652 | 656 | 660 | 664 | 668 |
| 670 | 672 | 676 | 680 | 684 | 688 | 690 | 692 | 696 | 700 | 704 | 708 | 710 | 712 | 716 | 720 | 724 | 728 |
| 730 | 732 | 736 | 740 | 744 | 748 | 750 | 752 | 756 | 760 | 764 | 768 | 770 | 772 | 776 | 780 | 784 | 788 |
| 790 | 792 | 796 | 800 | 804 | 808 | 810 | 812 | 816 | 820 | 824 | 828 | 830 | 832 | 836 | 840 | 844 | 848 |
| 850 | 852 | 856 | 860 | 864 | 868 | 870 | 872 | 875 | 876 | 880 | 884 | 888 | 890 | 892 | 896 | 900 | 904 |
| 908 | 910 | 912 | 916 | 920 | 924 | 925 | 928 | 930 | 932 | 936 | 940 | 944 | 948 | 950 | 952 | 956 | 960 |
| 964 | 968 | 970 | 972 | 975 | 976 | 980 | 984 | 988 | 990 | 992 | 996 | 1000 | 1004 | 1008 | 1010 | 1012 | 1016 |
| 1020 | 1024 | 1025 | 1028 | 1030 | 1032 | 1036 | 1040 | 1044 | 1048 | 1050 | 1052 | 1056 | 1060 | 1064 | 1068 | 1070 | 1072 |
| 1075 | 1080 | 1088 | 1090 | 1096 | 1100 | 1104 | 1110 | 1112 | 1120 | 1125 | 1128 | 1130 | 1136 | 1140 | 1144 | 1150 | 1152 |
| 1160 | 1168 | 1170 | 1175 | 1176 | 1180 | 1184 | 1190 | 1192 | 1200 | 1208 | 1210 | 1216 | 1220 | 1224 | 1225 | 1230 | 1232 |
| 1240 | 1248 | 1250 | 1256 | 1260 | 1264 | 1270 | 1272 | 1280 | 1288 | 1290 | 1296 | 1300 | 1304 | 1310 | 1312 | 1320 | 1325 |
| 1328 | 1330 | 1336 | 1340 | 1344 | 1350 | 1352 | 1360 | 1368 | 1370 | 1375 | 1376 | 1380 | 1384 | 1390 | 1392 | 1400 | 1408 |
| 1410 | 1416 | 1420 | 1424 | 1425 | 1430 | 1432 | 1440 | 1448 | 1450 | 1456 | 1460 | 1464 | 1470 | 1472 | 1475 | 1480 | 1488 |
| 1490 | 1496 | 1500 | 1504 | 1510 | 1512 | 1520 | 1525 | 1528 | 1530 | 1536 | 1540 | 1544 | 1550 | 1552 | 1560 | 1568 | 1570 |
| 1575 | 1576 | 1580 | 1584 | 1590 | 1592 | 1600 | 1608 | 1610 | 1616 | 1620 | 1624 | 1625 | 1630 | 1632 | 1640 | 1648 | 1650 |
| 1656 | 1660 | 1664 | 1670 | 1672 | 1672 | 1675 | 1680 | 1688 | 1690 | 1696 | 1700 | 1704 | 1710 | 1712 | 1720 | 1725 | 1728 |
| 1730 | 1736 | 1740 | 1744 | 1750 | 1752 | 1760 | 1768 | 1770 | 1775 | 1776 | 1780 | 1784 | 1790 | 1792 | 1800 | 1808 | 1810 |
| 1816 | 1820 | 1824 | 1825 | 1830 | 1832 | 1840 | 1848 | 1850 | 1856 | 1860 | 1864 | 1870 | 1872 | 1875 | 1880 | 1888 | 1890 |
| 1896 | 1900 | 1904 | 1910 | 1912 | 1920 | 1925 | 1928 | 1930 | 1936 | 1940 | 1944 | 1950 | 1952 | 1960 | 1968 | 1970 | 1975 |
| 1976 | 1980 | 1984 | 1990 | 1992 | 2000 | 2008 | 2010 | 2016 | 2020 | 2024 | 2025 | 2030 | 2032 | 2040 | 2048 | 2050 | 2056 |
| 2060 | 2064 | 2070 | 2072 | 2075 | 2080 | 2088 | 2090 | 2096 | 2100 | 2104 | 2110 | 2104 | 2110 | 2112 | 2120 | 2125 | 2128 |
| 2130 | 2136 | 2140 | 2144 | 2150 | 2160 | 2170 | 2175 | 2176 | 2180 | 2190 | 2192 | 2200 | 2208 | 2210 | 2220 | 2224 | 2225 |
| 2230 | 2240 | 2250 | 2256 | 2260 | 2270 | 2272 | 2275 | 2280 | 2288 | 2290 | 2300 | 2304 | 2310 | 2320 | 2325 | 2330 | 2336 |
| 2340 | 2350 | 2352 | 2360 | 2368 | 2370 | 2375 | 2380 | 2384 | 2390 | 2400 | 2410 | 2416 | 2420 | 2425 | 2430 | 2432 | 2440 |
| 2448 | 2450 | 2460 | 2464 | 2470 | 2475 | 2480 | 2490 | 2496 | 2500 | 2510 | 2512 | 2520 | 2525 | 2528 | 2530 | 2540 | 2544 |
| 2550 | 2560 | 2570 | 2575 | 2576 | 2580 | 2590 | 2592 | 2600 | 2608 | 2610 | 2620 | 2624 | 2625 | 2630 | 2640 | 2650 | 2656 |
| 2660 | 2670 | 2672 | 2675 | 2680 | 2688 | 2700 | 2704 | 2720 | 2725 | 2736 | 2740 | 2750 | 2752 | 2760 | 2768 | 2775 | 2780 |
| 2784 | 2800 | 2816 | 2820 | 2825 | 2832 | 2840 | 2848 | 2850 | 2860 | 2864 | 2875 | 2880 | 2896 | 2900 | 2912 | 2920 | 2925 |
| 2928 | 2940 | 2944 | 2950 | 2960 | 2975 | 2976 | 2980 | 2992 | 3000 | 3008 | 3020 | 3024 | 3025 | 3040 | 3050 | 3056 | 3060 |
| 3072 | 3075 | 3080 | 3088 | 3100 | 3104 | 3120 | 3125 | 3136 | 3140 | 3150 | 3152 | 3160 | 3168 | 3175 | 3180 | 3184 | 3200 |
| 3216 | 3220 | 3225 | 3232 | 3240 | 3248 | 3250 | 3260 | 3264 | 3275 | 3280 | 3296 | 3300 | 3312 | 3320 | 3325 | 3328 | 3340 |
| 3344 | 3350 | 3360 | 3375 | 3376 | 3380 | 3392 | 3400 | 3408 | 3420 | 3424 | 3425 | 3440 | 3450 | 3456 | 3460 | 3472 | 3475 |
| 3480 | 3488 | 3500 | 3504 | 3520 | 3525 | 3536 | 3540 | 3550 | 3552 | 3560 | 3568 | 3575 | 3580 | 3584 | 3600 | 3616 | 3620 |
| 3625 | 3632 | 3640 | 3648 | 3650 | 3660 | 3664 | 3675 | 3680 | 3696 | 3700 | 3712 | 3720 | 3725 | 3728 | 3740 | 3744 | 3750 |
| 3760 | 3775 | 3776 | 3780 | 3792 | 3800 | 3808 | 3820 | 3824 | 3825 | 3840 | 3850 | 3856 | 3860 | 3872 | 3875 | 3880 | 3888 |
| 3900 | 3904 | 3920 | 3925 | 3936 | 3940 | 3950 | 3952 | 3960 | 3968 | 3975 | 3980 | 3984 | 4000 | 4016 | 4020 | 4025 | 4032 |
| 4040 | 4048 | 4050 | 4060 | 4064 | 4075 | 4080 | 4096 | 4100 | 4112 | 4120 | 4125 | 4128 | 4140 | 4144 | 4150 | 4160 | 4175 |
| 4176 | 4180 | 4192 | 4200 | 4208 | 4220 | 4224 | 4225 | 4240 | 4250 | 4256 | 4260 | 4272 | 4275 | 4280 | 4288 | 4300 | 4320 |
| 4325 | 4340 | 4350 | 4352 | 4360 | 4375 | 4380 | 4384 | 4400 | 4416 | 4420 | 4425 | 4440 | 4448 | 4450 | 4460 | 4475 | 4480 |
| 4500 | 4512 | 4520 | 4525 | 4540 | 4544 | 4550 | 4560 | 4575 | 4576 | 4580 | 4600 | 4608 | 4620 | 4625 | 4640 | 4650 | 4660 |
| 4672 | 4675 | 4680 | 4700 | 4704 | 4720 | 4725 | 4736 | 4740 | 4750 | 4760 | 4768 | 4775 | 4780 | 4800 | 4820 | 4825 | 4832 |
| 4840 | 4850 | 4860 | 4864 | 4875 | 4880 | 4896 | 4900 | 4920 | 4925 | 4928 | 4940 | 4950 | 4960 | 4975 | 4980 | 4992 | 5000 |
| 5020 | 5024 | 5025 | 5040 | 5050 | 5056 | 5060 | 5075 | 5080 | 5088 | 5100 | 5120 | 5125 | 5140 | 5150 | 5152 | 5160 | 5175 |
| 5180 | 5184 | 5200 | 5216 | 5220 | 5225 | 5240 | 5248 | 5250 | 5260 | 5275 | 5280 | 5300 | 5312 | 5320 | 5325 | 5340 | 5344 |
| 5350 | 5360 | 5375 | 5376 | 5400 | 5408 | 5425 | 5440 | 5450 | 5472 | 5475 | 5480 | 5500 | 5504 | 5520 | 5525 | 5536 | 5550 |
| 5560 | 5568 | 5575 | 5600 | 5625 | 5632 | 5640 | 5650 | 5664 | 5675 | 5680 | 5696 | 5700 | 5720 | 5725 | 5728 | 5750 | 5760 |
| 5775 | 5792 | 5800 | 5824 | 5825 | 5840 | 5850 | 5856 | 5875 | 5880 | 5888 | 5900 | 5920 | 5925 | 5950 | 5952 | 5960 | 5975 |
| 5984 | 6000 | 6016 | 6025 | 6040 | 6048 | 6050 | 6075 | 6080 | 6100 | 6112 | 6120 | 6125 | 6144 | 6150 | 6160 | 6175 | 6176 |
| 6200 | 6208 | 6225 | 6240 | 6250 | 6272 | 6275 | 6280 | 6300 | 6304 | 6320 | 6325 | 6336 | 6350 | 6360 | 6368 | 6375 | 6400 |
| 6425 | 6432 | 6440 | 6450 | 6464 | 6475 | 6480 | 6496 | 6500 | 6520 | 6525 | 6528 | 6550 | 6560 | 6575 | 6592 | 6600 | 6624 |
| 6625 | 6640 | 6650 | 6656 | 6675 | 6680 | 6688 | 6700 | 6720 | 6750 | 6752 | 6760 | 6784 | 6800 | 6816 | 6840 | 6848 | 6850 |
| 6875 | 6880 | 6900 | 6912 | 6920 | 6944 | 6950 | 6960 | 6976 | 7000 | 7008 | 7040 | 7050 | 7072 | 7080 | 7100 | 7104 | 7120 |
| 7125 | 7136 | 7150 | 7160 | 7168 | 7200 | 7232 | 7240 | 7250 | 7264 | 7280 | 7296 | 7300 | 7320 | 7328 | 7350 | 7360 | 7375 |
| 7392 | 7400 | 7424 | 7440 | | | | | | | | | | | | | | |

